

---

**IMT/200**

VIDEOCITOTELEFONO  
VIDEO ENTRY TELEPHONE  
VIDEOSPRECHTELEFON  
MONITEUR VIDEO/TELEPHONE  
MONITOR CON TELEFONO  
VIDEOPORTEIRO  
COM TELEFONE

---

**ISTRUZIONI**

---

ITALIANO

---

**INSTRUCTIONS**

---

ENGLISH

**IMTC/200**

VIDEOCITOTELEFONO  
A COLORI  
COLOUR VIDEO  
ENTRY TELEPHONE  
FARBVIDEOSPRECHTELEFON  
MONITEUR VIDEO/TELEPHONE  
EN COULEURS  
MONITOR COLOR  
CON TELEFONO  
VIDEOPORTEIRO A CORES  
COM TELEFONE

---

**ANLEITUNG**

---

DEUTSCH

---

**INSTRUCTIONS**

---

FRANÇAIS

---

**INSTRUCCIONES**

---

ESPAÑOL

---

**INSTRUÇÕES**

---

PORTUGUÊS

---



---







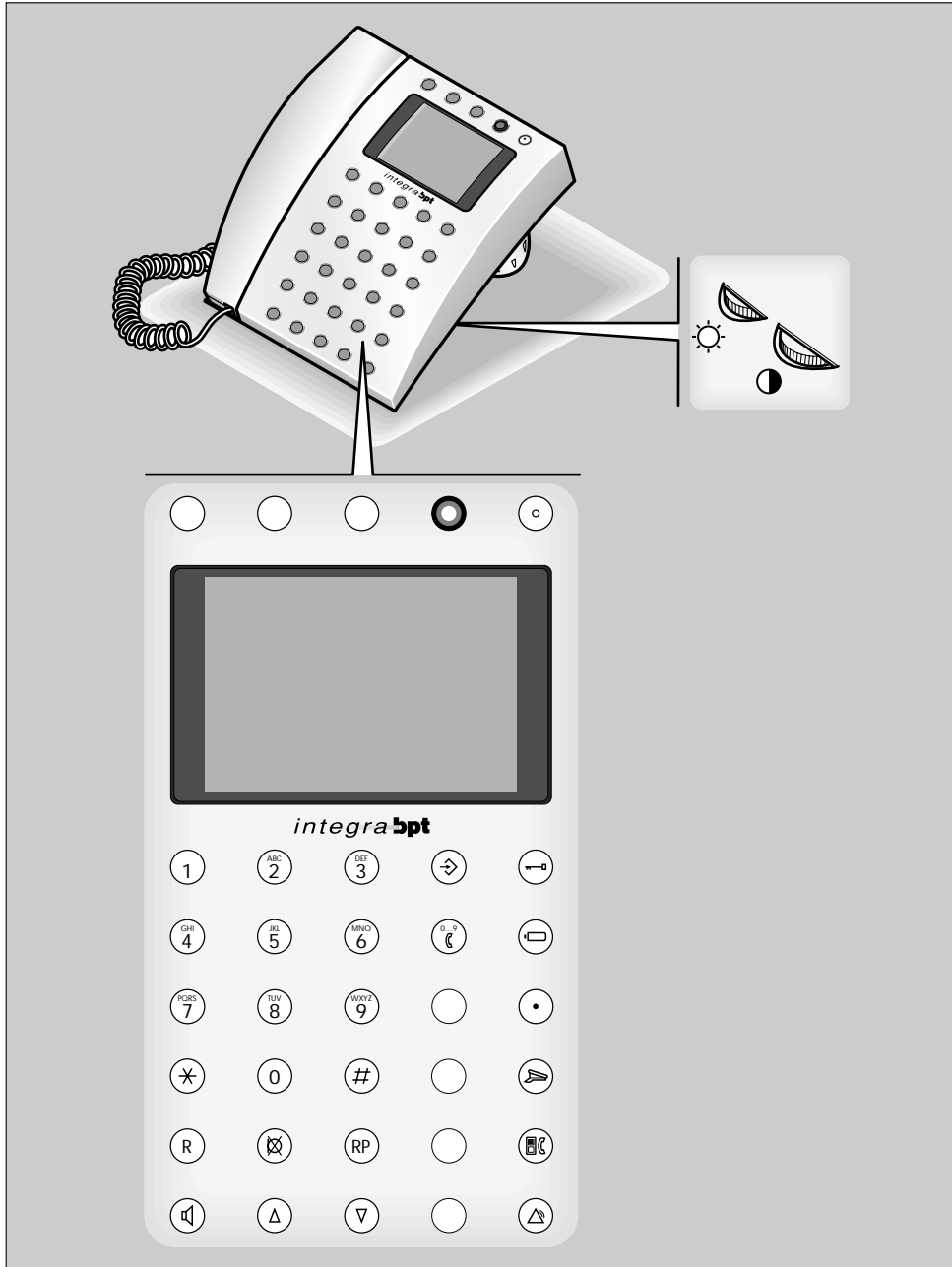





















## INDICE

Simbologia .....	4	<b>Istruzioni per l'utente</b>	
<b>Istruzioni per l'installatore</b>		<b>Utilizzo .....</b>	<b>15</b>
Avvertenze .....	6	- Chiamata .....	15
Generalità .....	7	- Chiamata viva-voce	
Collegamenti .....	8	(con cornetta agganciata) .....	15
<b>Programmazione .....</b>	<b>9</b>	- Tasto RP .....	15
- Configurazione di default .....	9	- Tasto mute .....	15
- Memorizzazione dei numeri brevi .....	9	- Tasto R (flash) .....	15
- Memorizzazione di un numero		- Tasto di servizio .....	16
per chiamata di servizio .....	10	- Tasto numeri brevi .....	16
- Impostazione della durata		- Tasti regolazione del volume	
del flash (tasto R) .....	10	in viva-voce .....	16
- Impostazione della durata		- Tasti funzione videocitofono .....	16
della pausa .....	11		
- Modifica del tipo di selezione .....	11		
- Impostazione del volume			
della suoneria .....	12		
- Impostazione della tonalità			
della suoneria .....	12		
- Selezione del tipo di apparecchiatura			
a cui il telefono viene connesso			
per le funzioni videocitofoniche .....	13		
- Ripristino della configurazione			
di default .....	13		
<b>Caratteristiche tecniche .....</b>	<b>14</b>		

## SIMBOLOGIA



## SIMBOLOGIA

			Tastiera telefonica 12 tasti standard		Tasto di servizio
					Regolazione luminosità (*)
					Regolazione contrasto mod. IMT/200 e saturazione colore mod. IMTC/200 (*)
				<b>LED</b>	Segnalatore luminoso rosso di modalità viva-voce. Durante la programmazione del telefono il LED è acceso.
				Tasto R (flash)	
				Tasto mute	
				Tasto RP (ripetizione ultimo numero)	
				Tasto viva-voce	
				Tasto incremento volume	
			Tasto decremento volume		
			Tasto di programmazione		
			Tasto numeri brevi		
			Tasto apriporta (*)		
			Tasto autoinserimento/selezione posto esterno (*)		
			Tasto ausiliario (*)		
			Tasto di chiamata portiere (*)		
			Tasto di commutazione videofono/telefono (*)		

ITALIANO

(\*) Comandi utilizzabili se l'apparecchio è collegato ad impianti videocitofonici.

---

## AVVERTENZE

ITALIANO

Leggere attentamente le avvertenze contenute nel seguente manuale in quanto forniscono importanti indicazioni riguardanti la sicurezza d'uso, d'installazione e manutenzione.

Dopo aver tolto l'imballaggio assicurarsi dell'integrità dell'apparecchio.

Gli elementi dell'imballaggio (sacchetti in plastica, polistirolo espanso, ecc.) non devono essere lasciati alla portata dei bambini in quanto potenziali fonti di pericolo.

Lo smaltimento degli imballi deve essere effettuato nel rispetto delle norme vigenti.

L'esecuzione dell'impianto deve essere rispondente alle norme di sicurezza vigenti.

**Non far passare i cavi telefonici in percorsi comuni a quelli dei cavi elettrici.**

Installare l'apparecchio in ambienti non polverosi, lontano da apparecchiature che possano generare disturbi elettrici di alta frequenza quali saldatrici, motori elettrici, forni a microonde, condizionatori d'aria, ecc.

Questo apparecchio dovrà essere destinato unicamente all'uso per il quale è stato espressamente concepito; qualunque uso diverso è da considerarsi improprio e pericoloso.

Il costruttore non può essere considerato responsabile per eventuali danni derivanti da usi impropri, erronei ed irragionevoli.

Per l'eventuale riparazione rivolgersi solamente ad un centro di assistenza tecnica autorizzato dal costruttore.

Il mancato rispetto di quanto sopra può compromettere la sicurezza dell'apparecchio.

L'installatore deve assicurarsi che le informazioni per l'utente, dove previste, siano presenti sugli apparecchi.

Tutti gli apparecchi costituenti l'impianto devono essere destinati esclusivamente per l'uso per cui sono stati concepiti.

---

## GENERALITA'

Videocitofono da tavolo IMT/200 (IMTC/200) completo di cavo multipolare (1,70 m) con spina per il collegamento alla presa e di cavo telefonico (2 m) per il collegamento alla linea telefonica urbana.

Mobile in ABS e schermo fumé.

L'apparecchio permette la connessione, tramite interfaccia IT/200, a reti telefoniche sia di tipo decadico sia di tipo multifrequenza ed ad impianti videocitofonici sistema 200.

E' munito di funzione viva-voce.

L'apparecchio è dotato di pulsanti dedicati per interagire in modo semplice con il sistema 200 videocitofonico **bpt** attraverso opportuna interfaccia telefonica.

### Funzioni principali

- Volume nota di chiamata regolabile.
- Funzione viva-voce.
- Compatibilità con sistema decadico o multifrequenza.
- Comandi per impianti videocitofonici (per l'attuazione di questi comandi è necessario l'uso dell'interfaccia telefonica o del PABX **bpt**).
- Non necessita di alimentatore supplementare.
- Durata pausa programmabile.
- Scansione posti esterni e/o telecamere supplementari.
- Autoinserimento.
- Comando apertura porta.
- Chiamata portiere.
- Comandi ausiliari.

ITALIANO



Cavo telefonico

## COLLEGAMENTI

### Connettore CN1

Viene utilizzato per il collegamento della cornetta all'apparecchio (fig. 1).

### Connettore CN2

Viene utilizzato per effettuare il collegamento alla linea telefonica urbana (fig. 1).

NOTA. L'apparecchio va collegato solo su linee telefoniche analogiche non su linee digitali ISDN.

### Funzione dei morsetti della presa

(vedi fig. 2)

- |   |                       |        |     |
|---|-----------------------|--------|-----|
| 1 | segnale video         | } cavo | (1) |
| 2 | schermo segnale video |        |     |
| 3 | segnale video         | } cavo |     |
| 4 | schermo segnale video |        |     |

(1) Se la linea non prosegue collegare una resistenza da 75  $\Omega$  (viola-verde-nero-oro) tra i morsetti 1 e 2.

- |   |                        |          |     |
|---|------------------------|----------|-----|
| 1 | segnale video positivo | } doppio | (2) |
| 2 | segnale video negativo |          |     |
| 3 | segnale video positivo | } doppio |     |
| 4 | segnale video negativo |          |     |

(2) Se la linea non prosegue collegare le due resistenze da 56  $\Omega$  (verde-blu-nero-oro) tra i morsetti 1-5 e 2-5.

- |   |                                     |   |
|---|-------------------------------------|---|
| 5 | -                                   | } 14 $\div$ 17,5V alimentazione monitor |
| 6 | +                                   |   |
| 7 | ingresso chiamata dal posto esterno |   |
| 8 | audio dal posto esterno             |   |

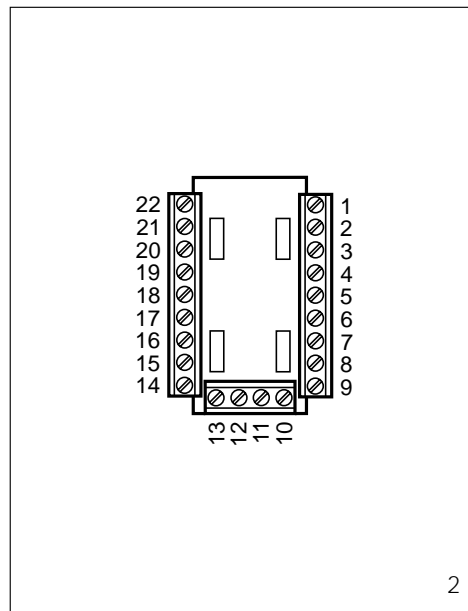
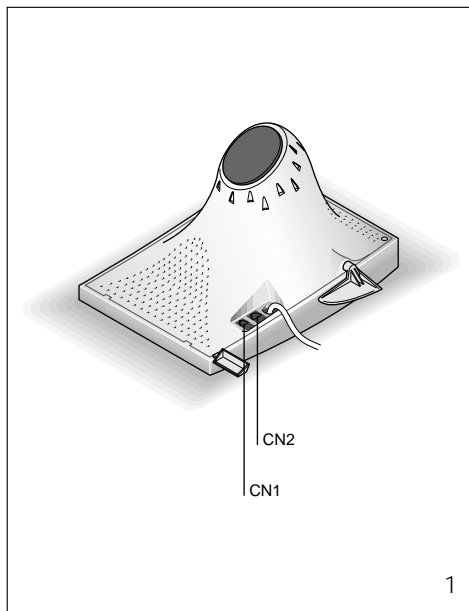



# PROGRAMMAZIONE

## Configurazione di default

- Volume di chiamata: 3 (livello massimo).
- Nota di chiamata: melodia 1.
- Volume viva-voce: 3 (livello massimo).
- Tipo di selezione linea: DTMF.
- Durata pausa: 1 s.
- Pulsante R (flash): 100 ms.
- Tasti funzione videocitofono: utilizzabili con l'interfaccia telefonica **bpt**.

Si può entrare in modo programmazione, sia con cornetta sollevata che in modalità viva-voce.

L'entrata in programmazione è segnalata dal LED rosso e dall'assenza del segnale di linea.

Per la programmazione di più funzioni non è necessario uscire e rientrare dalla modalità programmazione.

*Durante la programmazione la pressione dei tasti è accompagnata da un suono breve, la memorizzazione dei dati da un suono più lungo, gli errori da un suono prolungato.*

**AVVERTENZA.** Se la programmazione viene effettuata durante il collegamento con la linea urbana, dopo circa un minuto l'azione di dissuasione della centrale può disturbare il proseguo della programmazione.

In questo caso riagganciare la cornetta e riprendere la programmazione dal punto interrotto.

## Memorizzazione dei numeri brevi



Sollevare la cornetta

oppure

premere il tasto viva-voce.



Premere il tasto **PROGRAMMAZIONE**.



Premere il tasto **NUMERI BREVI**.

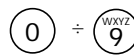

Premere il tasto a cui va associato il numero telefonico (**0÷9**).



Comporre il numero desiderato (max. 20 cifre) <sup>(1)</sup>.



Premere il tasto **NUMERI BREVI** per memorizzare.



Premere il tasto **PROGRAMMAZIONE**.



Riagganciare la cornetta

oppure

premere il tasto viva-voce.



Ripetere l'operazione per memorizzare il numero successivo. Si possono memorizzare fino a 10 numeri.

*(1) Se il videocitotelefono è collegato ad un centralino è necessario inserire una pausa tra lo 0 (numero per il passaggio alla linea urbana) e il numero telefonico.*

*Per inserire una pausa premere il tasto **RP**: es. **0 RP 0123 456789**.*

*La durata della pausa può essere raddoppiata premendo due volte il tasto **RP**.*

## PROGRAMMAZIONE

ITALIANO

### Memorizzazione di un numero per chiamata di servizio

Questa programmazione può essere utile, ad esempio, per chiamare un numero telefonico di uso frequente, oppure di evitare di comporre numeri ripetitivi, quali prefisso urbano o di altra rete di telefonia fissa.



Sollevare la cornetta  
oppure



premere il tasto viva-voce.



Premere il tasto **PROGRAMMAZIONE**.



Premere il tasto di **SERVIZIO**



Comporre il numero desiderato (max. 20 cifre) <sup>(1)</sup>.



Premere il tasto di **SERVIZIO** per memorizzare.



Premere il tasto **PROGRAMMAZIONE**.



Riagganciare la cornetta  
oppure



premere il tasto viva-voce.

### Impostazione della durata del flash (tasto R)



Sollevare la cornetta  
oppure



premere il tasto viva-voce.



Premere il tasto **PROGRAMMAZIONE**.



Premere il tasto **R**.

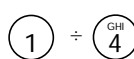

Premere il numero relativo alla durata che si intende impostare (**1+4**) (vedi capitolo **CARATTERISTICHE TECNICHE**).



Premere **R** per memorizzare.



Premere il tasto **PROGRAMMAZIONE**.



Riagganciare la cornetta  
oppure



premere il tasto viva-voce.

<sup>(1)</sup> Se il videocitofono è collegato ad un centralino è necessario inserire una pausa tra lo 0 (numero per il passaggio alla linea urbana) e il numero successivo.

Per inserire una pausa premere il tasto **RP**:  
es. **0 RP 0123 456789**.

La durata della pausa può essere raddoppiata premendo due volte il tasto **RP**.

## PROGRAMMAZIONE

### Impostazione della durata della pausa



Sollevare la cornetta

oppure



premere il tasto viva-voce.



Premere il tasto **PROGRAMMAZIONE**.



Premere il tasto **RP**.

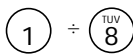

Premere il numero relativo alla durata che si intende impostare (**1÷8**) (vedi capitolo **CARATTERISTICHE TECNICHE**).



Premere **RP** per memorizzare.



Premere il tasto **PROGRAMMAZIONE**.



Riagganciare la cornetta

oppure



premere il tasto viva-voce.

### Modifica del tipo di selezione



Sollevare la cornetta

oppure

premere il tasto viva-voce.



Premere il tasto **PROGRAMMAZIONE**.



Premere il tasto **\*** per la selezione DTMF.



Premere il tasto **#** per la selezione DECADICA.



Premere il tasto **PROGRAMMAZIONE**.



Riagganciare la cornetta

oppure

premere il tasto viva-voce.



---

## PROGRAMMAZIONE

---

ITALIANO

### Impostazione del volume della suoneria



Sollevare la cornetta  
oppure



premere il tasto viva-voce.



Premere il tasto **PROGRAMMAZIONE**.



Premere il tasto **5**. Viene emessa dall'altoparlante la melodia della suoneria con il livello di volume precedentemente programmato.

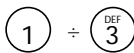

Premere i tasti **1÷3** per fissare il volume desiderato (vedi capitolo **CARATTERISTICHE TECNICHE**).



Premere nuovamente il tasto **5** per terminare l'impostazione.



Premere il tasto **PROGRAMMAZIONE**.



Riagganciare la cornetta  
oppure



premere il tasto viva-voce.

### Impostazione della tonalità della suoneria



Sollevare la cornetta  
oppure



premere il tasto viva-voce.



Premere il tasto **PROGRAMMAZIONE**.



Premere il tasto **6**. Viene emessa dall'altoparlante la melodia della suoneria con il livello di volume precedentemente programmato.

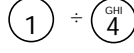

Premere i tasti **1÷4** per fissare la tonalità desiderata (vedi capitolo **CARATTERISTICHE TECNICHE**).



Premere nuovamente il tasto **6** per terminare l'impostazione.



Premere il tasto **PROGRAMMAZIONE**.



Riagganciare la cornetta  
oppure



premere il tasto viva-voce.

## PROGRAMMAZIONE

### Selezione del tipo di apparecchiatura a cui l'apparecchio viene connesso per le funzioni videocitofoniche



Solleverare la cornetta  
oppure



premere il tasto viva-voce.



Premere il tasto **PROGRAMMAZIONE**.



Premere il tasto 7.



Premere il tasto **1** se l'apparecchio é connesso con l'interfaccia telefonica **bpt**.



Premere il tasto **2** se l'apparecchio é connesso con un centralino telefonico PABX **bpt**.



Premere il tasto **7** per terminare l'impostazione.



Premere il tasto **PROGRAMMAZIONE**.



Riagganciare la cornetta  
oppure



premere il tasto viva-voce.

### Ripristino della configurazione di default



Solleverare la cornetta  
oppure



premere il tasto viva-voce.



Premere il tasto **PROGRAMMAZIONE**.



Premere due volte il tasto **0**.



Premere il tasto **PROGRAMMAZIONE**.



Riagganciare la cornetta  
oppure



premere il tasto viva-voce.

---

## CARATTERISTICHE TECNICHE

- Funzionamento viva-voce.
- Possibilità di memorizzare un numero per chiamata di servizio (20 cifre max.).
- Possibilità di memorizzare fino a 10 numeri telefonici (20 cifre max. per numero)
- Ripetizione dell'ultimo numero composto.
- Suoneria regolabile in volume a 3 livelli (minimo, medio, massimo).
- Suoneria regolabile in tonalità a 4 melodie.
- Comandi videocitofonici (apriporta, chiamata portiere, commutazione videocitofono/telefono, ausiliario/luce scale).
- Resistenza ingresso chiamata: 47 k $\Omega$ .
- Segnale di chiamata: bitonale.
- Durata flash regolabile: 1 = 100 ms, 2 = 120 ms, 3 = 300 ms, 4 = 600 ms.
- Durata pausa regolabile da 1 a 8 s: 1 = 1 s, ..., 8 = 8 s.
- Alimentazione telefono: dalla linea urbana o dall'interfaccia telefonica.
- Temperatura di funzionamento: da 0 °C a +35 °C.
- Umidità relativa: 90% senza condensa.

### Monitor b/n (mod. IMT/200)

- Standard video: CCIR (EIA).
- Cinescopio: 5" (12,5 cm) a 90°.
- Alimentazione: 14÷17,5 Vcc.
- Assorbimento: max. 600 mA (8 mA a riposo).
- Banda passante a -3 dB: 6 MHz.
- Ingresso video: 1 Vpp (da 0,5 a 1,5 Vpp) da linea coassiale; V+ 0,6 Vpp, V- 0,6 Vpp (da 0,3 a 0,9 Vpp) da linea differenziale (doppino telefonico).
- Impedenza d'ingresso video:  $\geq 22$  k $\Omega$ .
- Frequenza orizzontale: 15.625 Hz (15.750 Hz EIA).
- Frequenza verticale: 50 Hz (60 Hz EIA).

### Monitor a colori (mod. IMTC/200)

- Standard video: PAL.
- Display: LCD colore 4" a matrice attiva di 121.108 punti.
- Alimentazione: 14÷17,5 Vcc.

- Assorbimento: max. 500 mA (10 mA a riposo).
- Banda passante a -3 dB: 6 MHz.
- Ingresso video: 1 Vpp (da 0,5 a 1,5 Vpp) da linea coassiale; V+ 0,6 Vpp, V- 0,6 Vpp (da 0,3 a 0,9 Vpp) da linea differenziale (doppino telefonico).
- Impedenza d'ingresso video:  $\geq 22$  k $\Omega$ .

L'apparecchio è omologato secondo le norme CTR 37 e CTR 38 e soddisfa la norma EN 60950, relativa alla sicurezza elettrica, e la direttiva 89/336/EEC modificata con 93/68/EEC, relative alla compatibilità elettromagnetica.

Approvazione europea rilasciata dal TÜV Rheinland Product Safety GmbH

# CE 0197 X

---

## UTILIZZO

### Chiamata



Sollevare la cornetta.



Comporre il numero desiderato.



Al termine della conversazione, riagganciare la cornetta.

### Tasto MUTE



Premere il tasto **MUTE** se durante una conversazione telefonica si desidera impedire temporaneamente l'ascolto da parte dell'interlocutore (microfono, altoparlante e la cornetta vengono disattivati).



Premere nuovamente il tasto **MUTE** per riabilitare la conversazione.

ITALIANO

### Chiamata viva-voce (con cornetta agganciata)



Premere il tasto viva voce. Si accende il LED rosso.



Comporre il numero desiderato.



Al termine della conversazione, ripremere il tasto viva-voce.

### Tasto R (flash)



Questo tasto può venire usato quando il videocitotelefono è collegato ad un centralino telefonico.

Consultare il libretto di istruzioni del centralino usato per conoscere l'utilizzo del tasto **R**.

### Tasto RP



Sollevare la cornetta oppure



premere il tasto viva-voce.



Premere il tasto **RP** per effettuare la ripetizione dell'ultimo numero composto.

**ATTENZIONE.** Il tasto RP (ripetizione dell'ultimo numero composto) non è utilizzabile con i centralini CT/1-6 e CT/2-8.

---

## UTILIZZO

---

ITALIANO

### Tasto di SERVIZIO

Chiamata ad un numero telefonico di uso frequente



Premere il tasto di **SERVIZIO**.  
Il telefono si pone in modalità viva-voce e viene inviato il numero memorizzato.

### Chiamata tramite prefisso



Premere il tasto di **SERVIZIO**.  
Il telefono si pone in modalità viva-voce e viene inviato il prefisso memorizzato.



Comporre il numero desiderato.



Sollevare la cornetta se si vuole escludere la funzione viva-voce.

### Tasto NUMERI BREVI



Premere il tasto **NUMERI BREVI**.

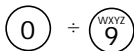

Premere il tasto (0-9) a cui è stato associato il numero telefonico desiderato.

### Tasti regolazione del volume in viva-voce



Usando i tasti **REGOLAZIONE VOLUME** durante la conversazione in viva-voce, il volume dell'altoparlante può essere incrementato o decrementato.

### Tasti funzione videocitofono



Ausiliario/Luce scale



Apriporta



Inserimento posto esterno



Chiamata portiere



Commutazione videocitofono/telefono

Questi tasti possono essere usati sia con l'apparecchio collegato ad una interfaccia telefonica **bpt** sia collegato ad un centralino PABX **bpt**.

I tasti **APRIPORTA** e **AUSILIARIO/LUCE SCALE** sono abilitati solo a seguito di una chiamata o autoinserimento.

*NOTA. Le funzioni videocitofoniche sono consentite solo con la cornetta sollevata o in modalità viva-voce.*

*L'autoinserimento è possibile anche con cornetta agganciata.*

**ATTENZIONE.** Il tasto **COMMUTAZIONE VIDEOCITOFONO /TELEFONO** non è utilizzabile con i centralini CT/1-6 e CT/2-8.



---

# CONTENTS

Symbols .....	18	<b>Instructions for the user</b>	
<b>Instructions for the installer</b>		<b>Operation .....</b>	<b>29</b>
Warnings .....	20	- Making call .....	29
Foreword .....	21	- Hands-free calls	
<b>Connections .....</b>	<b>22</b>	(with receiver hung up) .....	29
<b>Programming .....</b>	<b>23</b>	- RP key .....	29
- Default settings .....	23	- Mute key .....	29
- Storing one-touch numbers .....	23	- R key (flash) .....	29
- Storing service call number .....	24	- Service key .....	30
- Flash length setup (R key) .....	24	- One-touch dialling .....	30
- Pause length setup .....	25	- Hands-free volume control .....	30
- Changing dialling mode .....	25	- Video entry function keys .....	30
- Bell volume setup .....	26		
- Bell tone setup .....	26		
- Selecting the type of unit the			
telephone is to be connected to			
for the video entry functions .....	27		
- Resetting default settings .....	27		
<b>Technical features .....</b>	<b>28</b>		







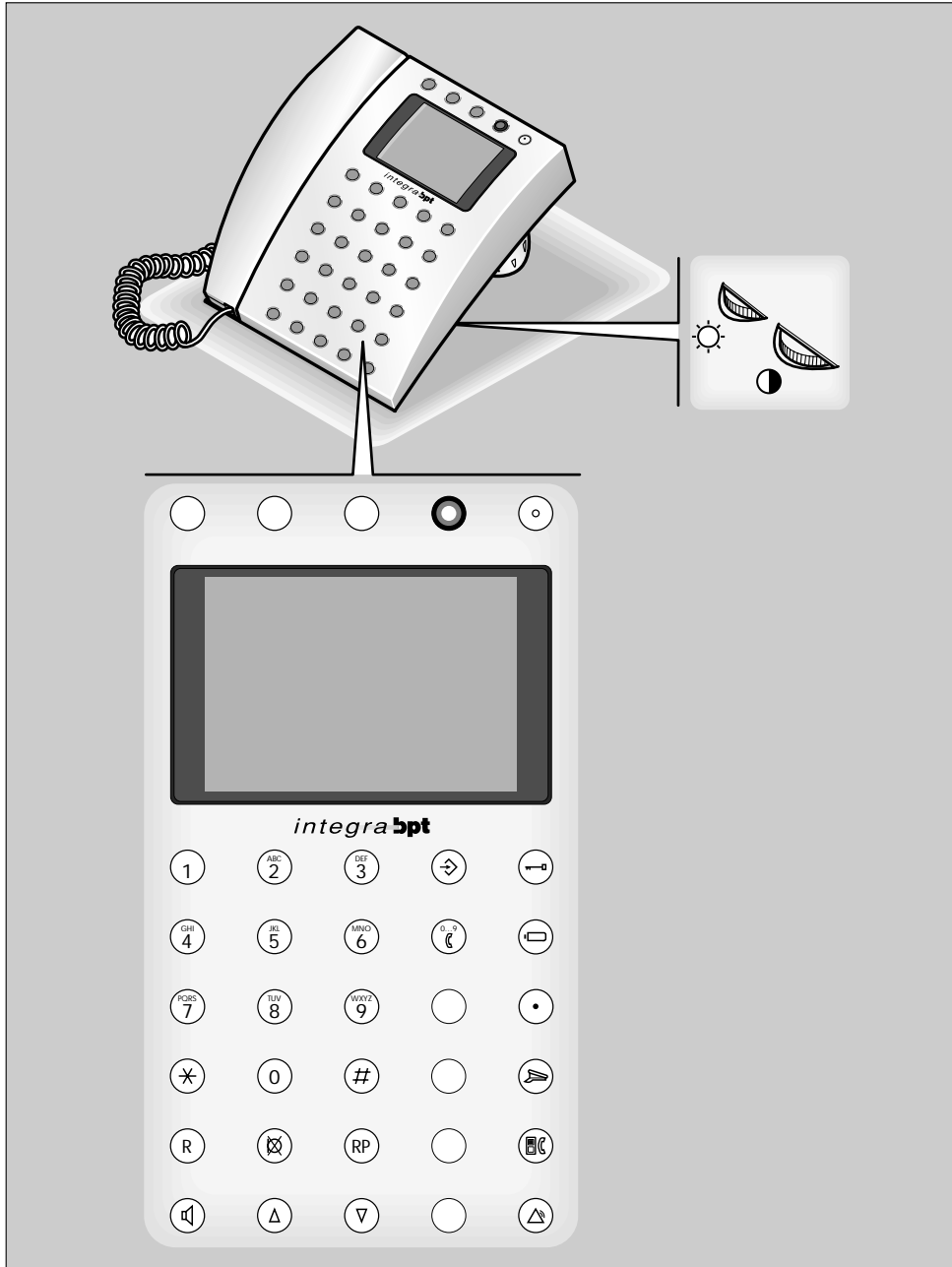





















ENGLISH

## SYMBOLS

ENGLISH



## SYMBOLS

			Telephone push-buttons 12 standard keys		Service key
					Brightness control (*)
					Contrast control mod. IMT/200 and colour saturation mod. IMTC/200 (*)
				<b>LED</b>	Red hands-free mode LED. During the programming of the telephone, the LED is lit.
	R key (flash)			<p>(*) Keys which can be used if the unit is connected to video entry control systems.</p>	
	Mute key				
	RP key (repeats last number)				
	Hands-free key				
	Increase volume key				
	Decrease volume key				
	Programming key				
	One-touch dialling key				
	Door lock release key (*)				
	Entry panel self-connection/selection key (*)				
	Auxiliary key (*)				
	Porter call key (*)				
	Entry video handset/telephone transfer key (*)				

ENGLISH

---

## WARNINGS

**Read the warnings contained herein carefully as they provide important instructions for safe operation, installation and maintenance.**

Having removed the packaging, make sure the unit is intact.

The packaging materials (plastic bags, foam polystyrene, etc.) must be kept out of the reach of children as they represent potential sources of danger.

The material must be disposed of according to the laws in force.

The installation of the system must comply with the safety rules in force.

**Do not run telephone cables in the same raceways as electrical cables.**

Install the unit in a fairly dust-free room, away from units liable to generate high-frequency electrical noise such as welding machines, electric motors, microwave ovens, air conditioners, etc.

This unit must be used only for the use for which it was explicitly designed; any other use shall be considered improper and hazardous.

The manufacturer cannot be held responsible for any damage as a result of improper, incorrect and unreasonable use.

When in need of repair work, contact only technical servicing centres authorized by the manufacturer.

Failure to comply with the above provisions may compromise the safety of the unit.

The installer must make sure that the user information, where applicable, is to be found on the unit.

All the equipment making up the system must be used only for the user for which they were designed.

---

## FOREWORD

Table-top video entry telephone IMT/200 (IMTC/200) complete with multipolar cable (1.70 m) with plug for connection to the socket and telephone cable (2 m) for connection to the local telephone line.

ABS housing and smoked screen.

The unit enables connection to both decadic and multifrequency telephone networks, and to system 200 video entry systems, by means of the IT/200 interface.

It features a hands-free function.

It comes complete with dedicated push-buttons used to interact in a simple manner with the **bpt** video entry control system via a telephone interface.

### Main functions

- Call bell volume control.
- Hands-free function.
- Compatibility with decadic or multifrequency systems.
- Video entry system controls (controls only enabled when using the **bpt** telephone interface or PABX).
- No supplementary power supplier needed.
- Programmable pause length.
- Scanning of entry panels and/or additional surveillance cameras.
- Self-connection to entry panel.
- Door-lock release control.
- Porter call.
- Auxiliary commands.

ENGLISH



Telephone cable

## CONNECTIONS

ENGLISH

### Connector M1

This is used for connecting the unit's receiver (fig. 1).

### Connector CN2

This is used for connecting the unit to the local telephone line (fig. 1).

**NOTE.** The unit must be connected on analogue telephone lines only and not digital ISDN lines.

### Function of socket terminal

(see fig. 2)

1 video signal } coaxial cable (1)

2 video signal shield

3 video signal } coaxial cable

4 video signal shield

(1) If the video line ends at this monitor, connect a 75 Ω (violet-green-black-gold) resistor between terminals 1 and 2.

1 positive video signal } twisted pair (2)

2 negative video signal

3 positive video signal } twisted pair

4 negative video signal

(2) If the video line ends at this monitor, connect the two 56 Ω (green-blue-black-gold) resistors between terminals 1-5 and 2-5.

5 - 14 ÷ 17.5V supply voltage to monitor

6 +

7 call input from entry panel

8 audio from entry panel

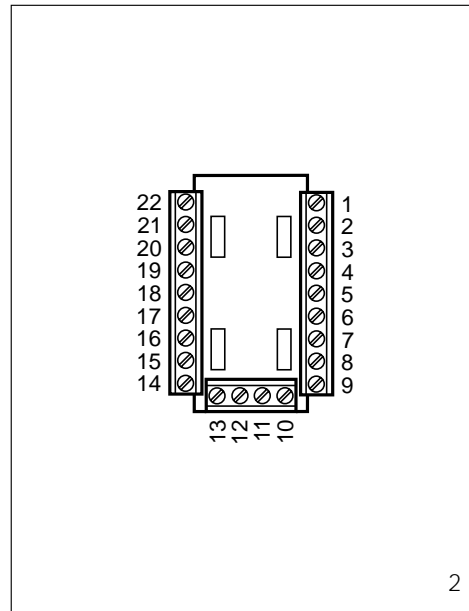
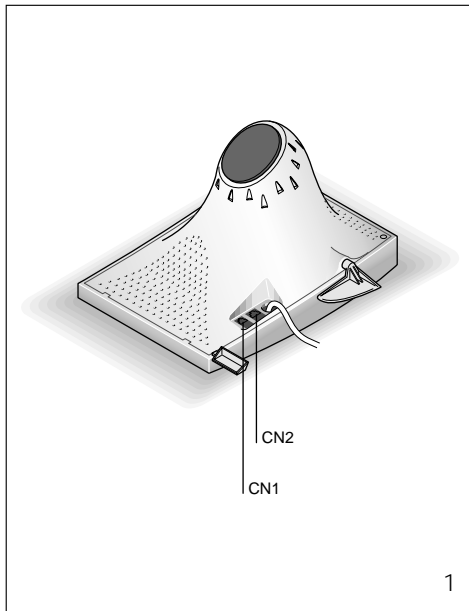

# PROGRAMMING

## Default settings

- Call volume: 3 (highest level).
- Call note: melody 1.
- Hands-free volume: 3 (highest level).
- Dialling mode: DTMF.
- Pause length: 1 s.
- R key (flash): 100ms.
- Video function keys: enabled with **bpt** telephone interface.

The programming mode can be entered either with the receiver lifted or in hands-free mode.

You can tell you have entered programming mode as the red LED comes on and there is no dial tone.

It is not necessary to exit and reenter the programming mode when programming a number of functions.

*During programming, pressing any of the keys produces a short beep, the storing of the data produces a longer sound, and errors an extended beep.*

**WARNING.** If the programming is carried out with the unit connected to the local line, after approx. one minute, the dissuasive action of the telephone exchange may interfere with programming. In this case, hang up the receiver and resume programming from where you left off.

## Storing one-touch numbers



Lift the receiver

or



press the hands-free key.



Press the **PROGRAMMING** key.



Press the **ONE-TOUCH DIAL** key.

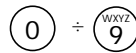

Press the key the telephone number is to be associated with (in the range 0 to 9).



Key in the desired number (max. 20 digits) (\*).



Press the **ONE-TOUCH DIAL** key to save.



Press the **PROGRAMMING** key.



Replace the receiver

or



press the hands-free key.

Repeat the operation to store the next number. Up to 10 different numbers can be stored.

(\**) If the video entry handset is connected to a switchboard, a pause must be inserted between the 0 (number dialled to get an outside line) and the **telephone number**.*

*To insert a pause, press the **RP** key e.g. 0 **RP** 0123 456789.*





*The length of the pause can be doubled by pressing the **RP** key twice.*

# PROGRAMMING









ENGLISH

## Storing service call number

This programming option may prove useful for calling a telephone number used frequently, for example, or to avoid dialling repetitive numbers, such as the area code or the code of another fixed telephone network.

-  Lift the receiver  
or  
press the hands-free key.
-  Press the **PROGRAMMING** key.
-  Press the **SERVICE** key.
-  Key in the desired number (max. 20 digits) (!).
-  Press the **SERVICE** key.
-  Press the **ONE-TOUCH DIAL** key to save.
-  Press the **PROGRAMMING** key.
-  Replace the receiver  
or  
press the hands-free key.

## Flash length setup (R key)

-  Lift the receiver  
or  
press the hands-free key.
-  Press the **PROGRAMMING** key.
-  Press the **R** key.
-   Press the number relating to the length to be set (in the range 1 to 4) (see section entitled TECHNICAL FEATURES).
-  Press **R** to save.
-  Press the **PROGRAMMING** key.
-  Replace the receiver  
or  
press the hands-free key.

(!) If the video entry handset is connected to a switchboard, a pause must be inserted between the 0 (number dialled to get an outside line) and the **telephone number**.

To insert a pause, press the **RP** key e.g. **0 RP 0123 456789**.

The length of the pause can be doubled by pressing the **RP** key twice.



---

## PROGRAMMING

### Pause length setup



Lift the receiver

or



press the hands-free key.



Press the **PROGRAMMING** key.



Press the **RP** key.

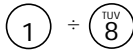

press the number relating to the length to be set (in the range **1** to **8**) (see section entitled TECHNICAL FEATURES).



Press **RP** to save.



Press the **PROGRAMMING** key.



Replace the receiver

or



press the hands-free key.

### Changing dialling mode



Lift the receiver

or



press the hands-free key.



Press the **PROGRAMMING** key.



Press the **\*** key for DTMF mode.



Press the **#** key for DECA-DIC mode.



Press the **PROGRAMMING** key.



Replace the receiver

or



press the hands-free key.

ENGLISH

---

## PROGRAMMING

ENGLISH

### Bell volume setup



Lift the receiver

or



press the hands-free key.



Press the **PROGRAMMING** key.



Press key **5**. The ring melody can be heard through the loudspeaker with the previously set volume level.

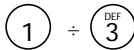

Press key in the range **1** to **3** to select the desired volume (see section entitled **TECHNICAL FEATURES**).



Press key **5** again to complete the setup.



Press the **PROGRAMMING** key.



Replace the receiver

or



press the hands-free key.

### Bell tone setup



Lift the receiver

or



press the hands-free key.



Press the **PROGRAMMING** key.



Press key **6**. The ring melody can be heard through the loudspeaker with the previously set volume level.

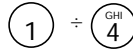

Press key in the range **1** to **4** to select the desired tone (see section entitled **TECHNICAL FEATURES**).



Press key **6** again to complete the setup.



Press the **PROGRAMMING** key.



Replace the receiver

or



press the hands-free key.

## PROGRAMMING

### Selecting the type of unit the telephone is to be connected to for the VIDEO entry functions



Lift the receiver  
or



press the hands-free key.



Press the **PROGRAMMING** key.



Press key **7**.



Press key **1** if the telephone is connected with the **bpt** telephone interface.



Press key **2** if the telephone is connected with a **bpt** PABX telephone switchboard.



Press key **7** to complete the setup.



Press the **PROGRAMMING** key.



Replace the receiver  
or



press the hands-free key.

### Resetting default settings



Lift the receiver

or



press the hands-free key.



Press the **PROGRAMMING** key.



Press key **0** twice.



Press the **PROGRAMMING** key.



Replace the receiver

or



press the hands-free key.

**WARNING.** By this operation all stored numbers will be cancelled.

ENGLISH

---

## TECHNICAL FEATURES

- Hands-free function.
- Possibility of storing a service call number (max. 20 digits).
- Possibility of storing up to 10 telephone numbers (max. 20 digits per number).
- Repeat function redials the last number.
- Bell volume control: 3 levels (low, medium, high).
- Adjustable bell tone: 4 melodies.
- Video entry controls (door lock release, porter call, video entry/telephone transfer, auxiliary function/stair light).
- Call input resistance: 47 k $\Omega$ .
- Two-tone call signal.
- Adjustable flash length: 1 = 100 ms, 2 = 120 ms, 3 = 300 ms, 4 = 600 ms.
- Adjustable pause length in the range 1 to 8 s: 1 = 1 s, ..., 8 = 8 s.
- Telephone power supply: from the local line or telephone interface.
- Working temperature range: from 0 °C to +35 °C.
- Relative humidity: 90% with no condensation.

### Black and white monitor (mod. IMT/200)

- Video standard: CCIR (EIA).
- CRT tube: 5" (12.5 cm) 90°.
- Supply voltage: 14÷17.5V DC.
- Current demand: 600 mA max. (8 mA quiescent).
- Bandwidth response at -3 dB: 6 MHz.
- Video input: 1 Vpp (0.5 to 1.5 Vpp) from coaxial line; V+ 0.6 Vpp, V- 0.6 Vpp (0.3 to 0.9 Vpp) from differential line (twisted pair).
- Video input impedance:  $\geq 22$  k $\Omega$ .
- Horizontal frequency: 15,625 Hz (15,750 Hz EIA).
- Vertical frequency: 50 Hz (60 Hz EIA).

### Colour monitor (mod. IMTC/200)

- Video standard: PAL.
- Display: 4" colour active matrix LCD with 121,108 dots.

- Supply voltage: 14÷17.5V DC.
- Current demand: 500 mA max. (10 mA quiescent).
- Bandwidth response at -3 dB: 6 MHz.
- Video input: 1 Vpp (0.5 to 1.5 Vpp) from coaxial line; V+ 0.6 Vpp, V- 0.6 Vpp (0.3 to 0.9 Vpp) from differential line (twisted pair).
- Video input impedance:  $\geq 22$  k $\Omega$ .

The unit is type approved according to standard CTR 37 and CTR 38 and meets the requirements of the EN 60950 standard relating to electrical safety, and of the 89/336/EEC directive amended with 93/68/EEC directive relating to electromagnetic compatibility.

European approval issued by  
TÜV Rheinland Product Safety GmbH

# CE 0197 X

---

## OPERATION

### Making calls



Lift the receiver.



Dial the desired number.



When the conversation is over, replace the receiver.

### Hands-free calls (with receiver hung up)



Press the hands-free key.  
The red LED lights.



Dial the desired number.



When the conversation is over, press the hands-free key again.

### RP key



Lift the receiver

or



press the hands-free key.



Press the **RP** key to repeat the last number dialled.

**WARNING.** The **RP** key (repeat the last number dialled) cannot be used with switchboards CT/1-6 and CT/2-8.

### MUTE key



Press the **MUTE** key when, during a telephone call, you want to talk, temporarily, without the person on the other end of the line listening in (microphone, receiver and loudspeaker are disabled).



Press the **MUTE** key again to resume the conversation.

### R key (flash)



This key can be used when the telephone is connected to a telephone switchboard. Consult the user manual of the switchboard used for instructions regarding the use of the **R** key.

---

## OPERATION

---

ENGLISH

### SERVICE key

Used to call a frequently dialled number



Press the **SERVICE** key. The telephone automatically switches to hands-free mode and the stored number is dialled.

Used to dial an area code



Press the **SERVICE** key. The telephone automatically switches to hands-free mode and the stored area code is dialled.



Dial the desired number.



Lift the receiver if you want to disable the hands-free function.

### ONE-TOUCH dialling



Press the **ONE-TOUCH DIAL** key.

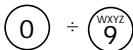

Press the key (in the range 0 to 9) associated with the telephone number desired.

### Hands-free volume control



The **VOLUME CONTROL** can be used during hands-free conversation to increase or decrease the volume of the loudspeaker.

### VIDEO ENTRY function keys



Auxiliary/Stair light



Door lock release



Inserimento posto esterno



Porter call



Entry video handset/telephone transfer.

These keys can be used when the unit is connected to either a **bpt** telephone interface or a **bpt** PABX switchboard.

The **DOOR LOCK RELEASE** and **AUXILIARY/STAIR LIGHT** keys are only enabled following a call or self-connection.

*NOTE.* The video entry functions can only be used with the receiver lifted or in hands-free mode.

*Self-connection to the entry panel is also possible with the receiver replaced.*

**WARNING.** The **ENTRY VIDEO HANDSET/TELEPHONE TRANSFER** key cannot be used with switchboards CT/1-6 and CT/2-8.

---

# INHALTSVERZEICHNIS

Zeichenerklärung .....	32	<b>Bedienungsanleitung</b>	
<b>Installationsanleitung</b>		<b>Benutzung .....</b>	<b>43</b>
Anmerkungen .....	34	- Anruf .....	43
Allgemeines .....	35	- Anruf mit Freisprechfunktion (mit angeschlossenem Hörer) .....	43
Anschlüsse .....	36	- RP-Taste .....	43
<b>Programmierung .....</b>	<b>37</b>	- Mute-Taste .....	43
- Standardkonfiguration .....	37	- R-Taste (Flash) .....	43
- Speichern von Kurwahlnummern .....	37	- Dienst-Taste .....	44
- Speichern einer Amtskennziffer .....	38	- Taste Kurzwahlruffnummern .....	44
- Eingabe der Flashdauer (R-Taste) .....	38	- Taste Lautstärkeregelung der Freisprechfunktion .....	44
- Eingabe der Pausendauer .....	39	- Sprech-/Videofunktionstasten .....	44
- Änderung des Anwählens .....	39		
- Regelung der Klingellautstärke .....	40		
- Regelung des Klingeltons .....	40		
- Auswahl des Gerätetyps, an dem das Telefon für die Videofunktionen anzu- schließen ist .....	41		
- Wiederherstellung der Standardkonfiguration .....	41		
<b>Technische Daten .....</b>	<b>42</b>		

DEUTSCH





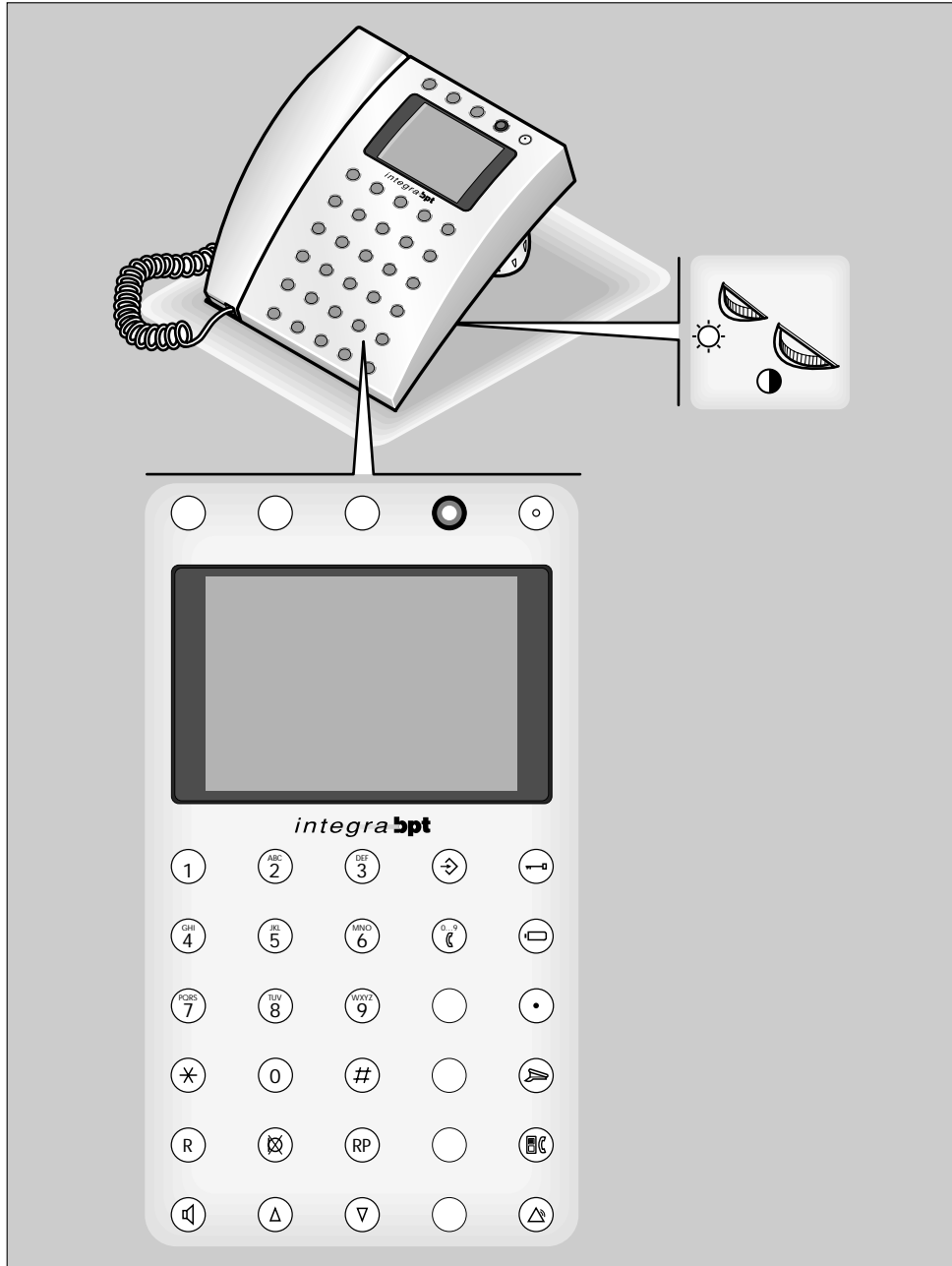

## ZEICHENERKLÄRUNG

DEUTSCH





## ZEICHENERKLÄRUNG

			Telefontastatur mit 12 Standardtasten		Diensttaste
					Regelung der Helligkeit
					Kontrastregelung mod. IMT/200 und Farbsättigung mod. IMTC/200 (!)
					
	R-Taste (Flash)			<b>LED</b>	Rote Leuchtanzeige des Freisprechmodus. Während der Programmierung des Telefons ist die LED an.
	Mutetaste				
	RP-Taste (Wahlwiederholung)				
	Freisprechfunktionstaste				
	Taste Lautstärkezunahme				
	Taste Lautstärkeabnahme				
	Programmiertaste				
	Kurzwahlrufnummerntaste				
	Türöffnertaste (!)				
	Taste zur Selbsteinschaltung/ Auswahl der Außenstation				
	Zusatztaste (!)				
	Pfortnerruftaste (!)				
	Umschalttaste Videosprechgar- nitur/Telefon (!)				

(!) Benutzbare Tasten, falls das Gerät an Videosprechanlagen angeschlossen ist.

DEUTSCH

---

## ANMERKUNGEN

Die Anmerkungen der nachfolgenden Anleitung aufmerksam durchlesen, da sie wichtige Sicherheitshinweise über die Benutzung, Installation und Wartung liefern.

Verpackung abnehmen und sicherstellen, daß das Gerät einwandfrei ist.

Die Verpackungsteile (Plastikbeutel, Schaum- polystyrol, etc.) müssen außerhalb der Reichweite von Kindern aufbewahrt werden, da diese eine Gefahrenquelle darstellen können.

Die Verpackungsteile nicht in die Umwelt freisetzen, sondern sich an die geltenden Gesetze halten.

Der Anlagenbau muß den geltenden Sicherheitsvorschriften entsprechen.

**Telefonkabel nicht zusammen mit elektrischen Kabeln legen.**

Gerät nicht an einem staubigen Ort und fern von Geräten, die elektrische Hochfrequenzstörungen verursachen können, wie Schweißapparate, elektrische Motoren, Mikrowellenherd, Klimaanlage, etc. aufstellen.

Dieses Gerät ausschließlich für die eigens hierfür gedachte Benutzung gebrauchen; eine Zweckentfremdung ist unangebracht und somit gefährlich.

Der Hersteller übernimmt keine Haftung für eventuelle Schäden, die auf eine Zweckentfremdung, eine falsche oder unvernünftige Bedienung zurückzuführen sind.

Im Falle einer Reparatur sich ausschließlich an eine vom Hersteller dazu ermächtigte Kundendienststelle wenden.

Die mangelnde Beachtung des oben Genannten kann die Sicherheit des Geräts beeinträchtigen.

Der Installateur muß sich vergewissern, daß die für den Benutzer erforderlichen Informationen auf der dafür vorgesehenen Stelle auf den Geräten vorhanden sind.

Alle Anlagengeräte dürfen ausschließlich für die hierfür gedachte Benutzung verwendet werden.

---

## ALLGEMEINES

Videotürsprechtelefon als Tischausführung IMT/200 (IMTC/200), ausgestattet mit Mehrleiterkabel (1,70 m) mit Stecker für den Netzanschluß und Telefonkabel (2 m) für den Anschluß an das Ortsnetz.

ABS-Gehäuse und getönte Acrylglasplatte. Durch das Gerät können über die Schnittstelle IT/200 Anschlüsse an Digital- oder Mehrfrequenz-Telefonnetze sowie an Videotürsprechanlagen des Systems 200 vorgenommen werden.

Es ist mit einer Freisprechfunktion ausgerüstet und besitzt Tasten zur einfachen Umschaltung zwischen der **bpt** Haussprech- und Videotürsprechanlage an der Telefonschnittstelle **bpt**.

### Funktionen

- Lautstärkeregelung des Ruftons.
- Freisprechfunktion.
- Kompatibilität mit IWW- oder MFV-Systemen.
- Schaltfunktionen für Videosprechanlagen (für die Einschaltung dieser Funktionen ist die Benutzung der Telefonschnittstelle oder **bpt** PABX erforderlich).
- Kein zusätzliches Netzgerät erforderlich.
- Programmierbare Pausendauer.
- Abtastung der Außenstationen und/oder Zusatzkameras.
- Selbsteinschaltung.
- Steuerung des Türöffners.
- Pförtneranruf.
- Zusatzsteuerungen.

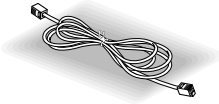

Telefonkabel

DEUTSCH

# ANSCHLÜSSE

## Buchse CN1

Wird für den Anschluß des Hörers an das Gerät benutzt (Abb. 1).

## Buchse CN2

Wird für den Anschluß an das Ortsnetz benutzt (Abb. 1).

**HINWEIS.** Das Gerät darf nur an analogen und nicht an digitalen ISDN-Telefonleitungen angeschlossen werden.

## Belegung der Klemmleisten der Steckdose

(siehe Abb. 2)

- |   |                        |            |                      |
|---|------------------------|------------|----------------------|
| 1 | Videosignal            | } Koaxial- | kabel <sup>(1)</sup> |
| 2 | Videosignalabschirmung |            |                      |
| 3 | Videosignal            | } Koaxial- | kabel                |
| 4 | Videosignalabschirmung |            |                      |

<sup>(1)</sup> Am ende der Linie ist ein Widerstand von 75 Ω (violett-grün-schwarz-gold) zwischen den Klemmen 1 und 2 einzusetzen.

- |   |                     |            |                      |
|---|---------------------|------------|----------------------|
| 1 | Videosignal Positiv | } Telefon- | kabel <sup>(2)</sup> |
| 2 | Videosignal Negativ |            |                      |
| 3 | Videosignal Positiv | } Telefon- | kabel                |
| 4 | Videosignal Negativ |            |                      |

<sup>(2)</sup> Am ende der Linie ist zwei Widerstand von 56 Ω (grün-blau-schwarz-gold) zwischen den Klemmen 1-5 und 2-5 einzusetzen.

- |   |                                |                                |
|---|--------------------------------|--------------------------------|
| 5 | -                              | } 14 ÷ 17,5V Monitorversorgung |
| 6 | +                              |                                |
| 7 | Anrufeingänge von Außenstation |                                |
| 8 | Audio von Außenstation         |                                |

DEUTSCH

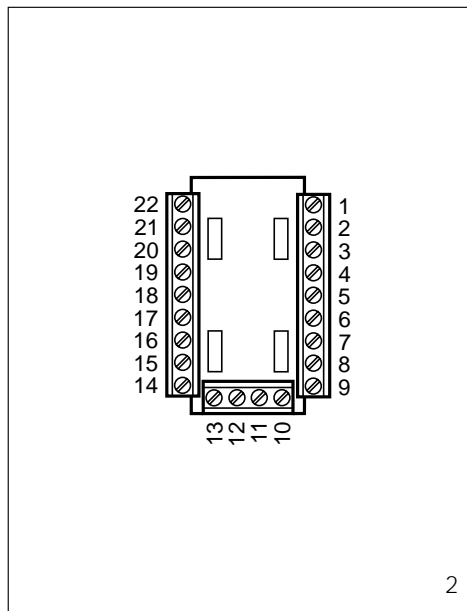
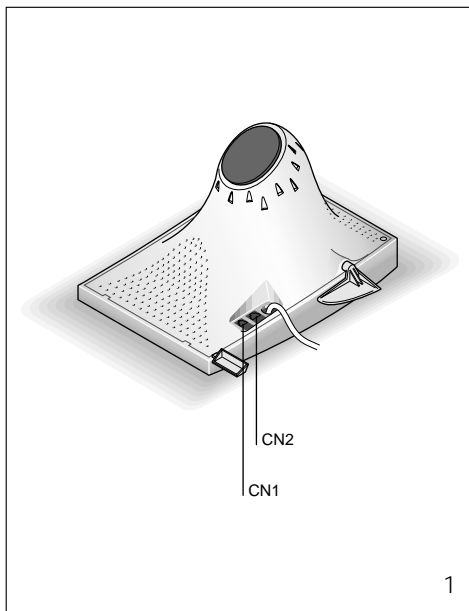

# PROGRAMMIERUNG

## Standardkonfiguration

- Rufonlautstärke: 3 (max. Pegel).
- Rufton: Melodie 1.
- Lautstärke der Freisprechfunktion: 3 (max. Pegel).
- Wählart der Leitung: MFV.
- Pausendauer: 1s.
- R-Taste (Flash): 100 ms.
- Videofunktionstasten: mit **bpt** Telefonschnittstelle benutzbar.

Der Programmiermodus ist sowohl bei abgehobenem Hörer als auch mit der Freisprechfunktion möglich.

Der Programmierbeginn wird durch die Einschaltung der roten Led und das Fehlen des Freizeichens angezeigt.

Falls mehrere Funktionen zu programmieren sind, ist die Beendigung und der Rückruf des Vorgangs Programmiermodus nicht erforderlich.

*Bei der Programmierung wird der Tastendruck von einem Kurztone, die Datenspeicherung von einem längeren Ton, eventuelle Fehler von einem anhaltenden Ton quittiert.*

ANMERKUNG. Falls die Programmierung während der Verbindung mit der Ortsleitung erfolgt, könnte nach circa einer Minute das Fortsetzen der Programmierung durch das Abschreckungsverfahren der Zentrale gestört werden.

In diesem Fall Hörer wieder auflegen und Programmierung an der unterbrochenen Stelle wieder aufnehmen.

## Speichern von Kurzwahlnummern



Hörer abnehmen

oder



Taste Freisprechfunktion drücken.



Taste **PROGRAMMIERUNG** drücken.



Taste **KURZWAHLNUMMERN** drücken.

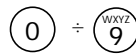

Die Taste, der die Telefonnummer zugeordnet ist, drücken (0÷9).



Die gewünschte Rufnummer wählen (max. 20 Ziffern) (\*).



Zur Speicherung Taste **KURZWAHLNUMMERN** drücken.



Taste **PROGRAMMIERUNG** drücken.



Hörer wieder auflegen

oder



Taste Freisprechfunktion drücken.

Um die darauffolgende Rufnummer zu speichern, Vorgang wiederholen. Es können bis zu 10 Rufnummern gespeichert werden.

(\*) Falls das Videosprechtelefon an eine Telefonzentrale angeschlossen ist, ist zwischen der 0 (als möglicher Amtskennziffer) und der Telefonnummer eine Pause einzugeben. Zur Pauseneingabe RP-Taste drücken, z. Bsp. : 0 RP 0123 456789.

Durch zweimaligen RP-Tastendruck kann die Pausendauer verdoppelt werden.

DEUTSCH

## PROGRAMMIERUNG

### Speichern einer Amtskennziffer

Diese Programmierung kann nützlich sein, um zum Beispiel eine häufig gewählte Telefonnummer zu wählen oder um sich ständig wiederholende Nummern wie die Ortskennzahl oder die Vorwahl eines anderen festen Telefonnetzes zu vermeiden.



Hörer abnehmen

oder



Taste Freisprechfunktion drücken.



Taste **PROGRAMMIERUNG** drücken.



**DIENST**-Taste drücken.



Die gewünschte Rufnummer wählen (max. 20 Ziffern (\*)).



Zur Speicherung **DIENST**-Taste drücken.



Taste **PROGRAMMIERUNG** drücken.



Hörer wieder auflegen  
oder



Taste Freisprechfunktion drücken.

DEUTSCH

### Eingabe der Pausendauer (R-Taste)



Hörer abnehmen

oder



Taste Freisprechfunktion drücken.



Taste **PROGRAMMIERUNG** drücken.



**R**-Taste drücken.

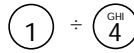

Die jeweilige Nummer der einzugebenden Dauer (**1÷4**) drücken (siehe Kapitel TECHNISCHE DATEN).



Zur Speicherung **R**-Taste drücken.



Taste **PROGRAMMIERUNG** drücken.



Hörer wieder auflegen  
oder



Taste Freisprechfunktion drücken.

(\*) Falls das Videosprechtelefon an eine Telefonzentrale angeschlossen ist, ist zwischen der 0 (als möglicher Amtskennziffer) und der Telefonnummer eine Pause einzugeben.

Zur Pauseneingabe **RP**-Taste drücken, z. Bsp. : 0 **RP** 0123 456789.

Durch zweimaliger **RP**-Tastendruck kann die Pausendauer verdoppelt werden.

## PROGRAMMIERUNG

### Eingabe der Pausendauer



Hörer abnehmen  
oder



Taste Freisprechfunktion  
drücken.



Taste **PROGRAMMIERUNG**  
drücken.



**RP**-Taste drücken.

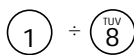

Die jeweilige Nummer der  
einzugebenden Dauer (1÷8)  
drücken (siehe Kapitel  
TECHNISCHE DATEN).



Zur Speicherung **RP**-Taste  
drücken.



Taste **PROGRAMMIERUNG**  
drücken.



Hörer wieder auflegen  
oder



Taste Freisprechfunktion  
drücken.

### Änderung des Anwählens



Hörer abnehmen  
oder



Taste Freisprechfunktion  
drücken.



Taste **PROGRAMMIERUNG**  
drücken.



Für die MFV-Wählart Taste **\***  
drücken.



Für die IWV-Wählart Taste **#**  
drücken.



Taste **PROGRAMMIERUNG**  
drücken.



Hörer wieder auflegen  
oder



Taste Freisprechfunktion  
drücken.

DEUTSCH

---

## PROGRAMMIERUNG

### Regelung der Klingellautstärke



Hörer abnehmen  
oder



Taste Freisprechfunktion  
drücken.



Taste **PROGRAMMIERUNG**  
drücken.



Taste **5** drücken. Der  
Lautstärker sendet die  
Klingelmelodie mit der zuvor  
eingestellten Lautstärke.

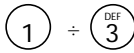

Tasten **1÷3** drücken, um die  
gewünschte Lautstärke  
(siehe Kapitel TECHNISCHE  
DATEN) zu bestimmen.



Erneut Taste **5** drücken, um  
die Einstellung zu beenden.



Taste **PROGRAMMIERUNG**  
drücken.



Hörer wieder auflegen  
oder



Taste Freisprechfunktion  
drücken.

### Regelung des Klingeltons



Hörer abnehmen  
oder



Taste Freisprechfunktion  
drücken.



Taste **PROGRAMMIERUNG**  
drücken.



Taste **6** drücken. Der  
Lautstärker sendet die  
Klingelmelodie mit der zuvor  
eingestellten Lautstärke.

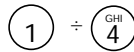

Tasten **1÷4** drücken, um den  
gewünschten Klingelton  
(siehe Kapitel TECHNISCHE  
DATEN) zu bestimmen.



Erneut Taste **6** drücken, um  
die Einstellung zu beenden.



Taste **PROGRAMMIERUNG**  
drücken.



Hörer wieder auflegen  
oder



Taste Freisprechfunktion  
drücken.

DEUTSCH



---

## PROGRAMMIERUNG

### Auswahl des Gerätetyps, an dem das Telefon für die VIDEOfunktionen anzuschließen ist



Hörer abnehmen  
oder



Taste Freisprechfunktion  
drücken.



Taste **PROGRAMMIERUNG**  
drücken.



Taste **7** drücken.



Taste **1** drücken, wenn das  
Telefon an die **bpt**-Telefon-  
schnittstelle angeschlossen  
ist.



Taste **2** drücken, wenn das  
Telefon an eine **bpt**-Telefon-  
zentrale PABX angeschlossen  
ist.



Erneut Taste **7** drücken, um  
die Einstellung zu beenden.



Taste **PROGRAMMIERUNG**  
drücken.



Hörer wieder auflegen  
oder



Taste Freisprechfunktion  
drücken.

### Wiederherstellung der Standardkonfiguration



Hörer abnehmen  
oder



Taste Freisprechfunktion  
drücken.



Taste **PROGRAMMIERUNG**  
drücken.



Zweimal Taste **0** drücken.



Taste **PROGRAMMIERUNG**  
drücken.



Hörer wieder auflegen  
oder



Taste Freisprechfunktion  
drücken.

**ACHTUNG.** Durch diese Maßnahme wer-  
den alle gespeicherten Telefonnummern gelö-  
scht.

DEUTSCH

---

## TECHNISCHE DATEN

- Freisprechfunktion.
- Speichern einer Amtskennziffer (max. 20 Ziffern).
- Speichern von bis zu 10 Telefonnummern (max. 20 Ziffern pro Nummer).
- Wahlwiederholung der zuletzt gewählten Rufnummer.
- Regelbare 3-Stufen-Klingellautstärke (schwach-mittel-laut).
- Regelbarer Klingelton mit 4 Melodien.
- Steuerfunktionen der Videosprechanlage (Türöffner, Pförtneranruf, Umschaltung Videosprechgarnitur/Telefon, Zusatzfunktion / Treppenlicht).
- Widerstand Rufeingang: 47 k $\Omega$ .
- Rufsignal: zwei Ruftöne.
- Regelbare Flashdauer: 1 = 100 ms, 2 = 120 ms, 3 = 300 ms, 4 = 600 ms.
- Pausendauer regelbar zwischen 1 bis 8 s: 1 = 1 s, ..., 8 = 8 s.
- Telefonstromversorgung: erfolgt durch die Amtsleitung oder Telefonschnittstelle.
- Betriebstemperatur: von 0 °C bis +35 °C.
- Relative Luftfeuchtigkeit: 90% ohne Kondenswasser.

### Weiß/Schwarz Monitor IMT/200

- Stromversorgung: 14÷17,5V DC.
- Stromaufnahme: 600 mA max. (8 mA Ruhestrom).
- Bildröhre: CRT 5-Zoll (12,5 cm) - 90° Ablenkung.
- CCIR Standard (EIA Standard).
- Video-Eingangsimpedanz:  $\geq 22$  k $\Omega$ .
- Durchlaßbereich: 6 MHz bei -3 dB.
- Videoeingang: 1 Vss (0,5 bis 1,5 Vss) von Koaxialkabel; V+ 0,6 Vss, V- 0,6 Vss (0,3 bis 0,9 Vss) von Differentialleitung (Telefonkabel).
- Horizontalfrequenz: 15.625 Hz (15.750 Hz EIA).
- Vertikalfrequenz: 50 Hz (60 Hz EIA).

### Farbmonitor IM/TC

- Stromversorgung: 14÷17,5 V DC.
- Stromaufnahme: 500 mA max. (10 mA Ruhestrom).
- Bildschirm: 4" LCD farbig mit aktiver Matrix zu 121.108 Bildpunkten.
- PAL Standard.
- Video-Eingangsimpedanz:  $\geq 22$  k $\Omega$ .
- Durchlaßbereich: 6 MHz bei -3 dB.
- Videoeingang: 1 Vss (0,5 bis 1,5 Vss) von Koaxialkabel; V+ 0,6 Vss, V- 0,6 Vss (0,3 bis 0,9 Vss) von Differentialleitung (Telefonkabel).

Das Gerät wurde gemäß den Vorschriften CTR 37 und CTR 38 zugelassen und erfüllt die Vorschrift EN 60950 über die elektrische Sicherheit und die europäische Richtlinie 89/336/EEC, durch 93/68/EEC abgeändert, über die elektromagnetische Kompatibilität.

Die europäische Genehmigung wurde von TÜV Rheinland Product Safety GmbH erlassen

# CE 0197 X

---

## BENUTZUNG

### Anruf



Hörer abnehmen.



Die gewünschte Rufnummer wählen.



Nach Gesprächsende, Hörer wieder auflegen.

### Anruf mit Freisprechfunktion (mit angeschlossenem Mikrotelefon)



Taste Freisprechfunktion drücken.  
Die rote LED leuchtet auf.



Die gewünschte Rufnummer wählen.



Nach Gesprächsende, Freisprechfunktionstaste drücken.

### RP-Taste



Hörer abnehmen  
oder



Taste Freisprechfunktion drücken.



**RP**-Taste drücken, um die zuletzt gewählte Rufnummer wiederholen.

**ACHTUNG.** Die **RP**-Taste (Wiederholung der zuletzt gewählten Rufnummer) ist mit den Telefonzentralen CT/1-6 und CT/2-8 nicht benutzbar.

### MUTE-Taste



**MUTE**-Taste drücken, wenn während eines Telefongesprächs das Zuhören des Gesprächsteilnehmers verhindert werden soll (Mikrofon, Hörer und Lautsprecher werden ausgeschaltet).



Erneut **MUTE**-Taste drücken, um das Gespräch wieder aufzunehmen.

### R-Taste (Flash)



Diese Taste kann nur dann verwendet werden, wenn das Videosprechtelefon an eine Telefonzentrale angeschlossen ist. Zur Verwendung der **R**-Taste ist die Betriebsanleitung der verwendeten Zentrale durchzulesen.

DEUTSCH

## BENUTZUNG

### DIENST-Taste

Anwählen einer häufig verwendeten Rufnummer



**DIENST**-Taste drücken. Das Telefon schaltet die Freisprechfunktion ein und sendet die gespeicherte Vorwahl.

### Anruf mit Vorwahl



**DIENST**-Taste drücken. Das Telefon schaltet die Freisprechfunktion ein und sendet die gespeicherte Vorwahl.

DEUTSCH



Die gewünschte Rufnummer wählen.



Hörer abheben, wenn die Freisprechfunktion eingeschaltet werden soll.

### Taste

#### KURZWÄHLRUFNUMMERN



Taste **KURZWÄHLRUFNUMMERN** drücken.

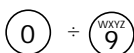

Die Taste (0÷9), der die gewünschte Telefonnummer zugeordnet ist, drücken.

### Taste Lautstärkeregelung der Freisprechfunktion



Durch das Drücken der Taste **LAUTSTÄRKEREGLUNG** während des Gesprächs mit eingeschalteter Freisprechfunktion, kann die Lautstärke des Lautsprechers erhöht oder reduziert werden.

### SPRECH-/VIDEOfunktionstasten



Zusatzfunktion/Treppenlicht



Türöffner



Einschaltung der Außenstation



Pförtneranruf



Umschaltung Videosprechgarnitur/Telefon

Diese Tasten können sowohl bei einem an eine **bpt** Telefonschnittstelle als auch an eine **bpt** Zentrale PABX angeschlossenes Telefon verwendet werden.

Die Tasten **TÜRÖFFNER** und **ZUSATZFUNKTION/TREPPENLICHT** sind nur infolge eines Anrufs oder ihrer Selbsteinschaltung einschaltbar.

***ANMERKUNG.** Die Videofunktionen sind nur bei abgehobenem Hörer oder bei eingeschalteter Freisprechfunktion möglich.*

*Die Selbsteinschaltung ist auch bei eingehängtem Hörer möglich.*

**ACHTUNG.** Die Taste **UMSCHALTUNG VIDEOSPRECHGARNITUR/TELEFON** ist mit den Telefonzentralen CT/1-6 und CT/2-8 nicht benutzbar.

---

## SOMMAIRE







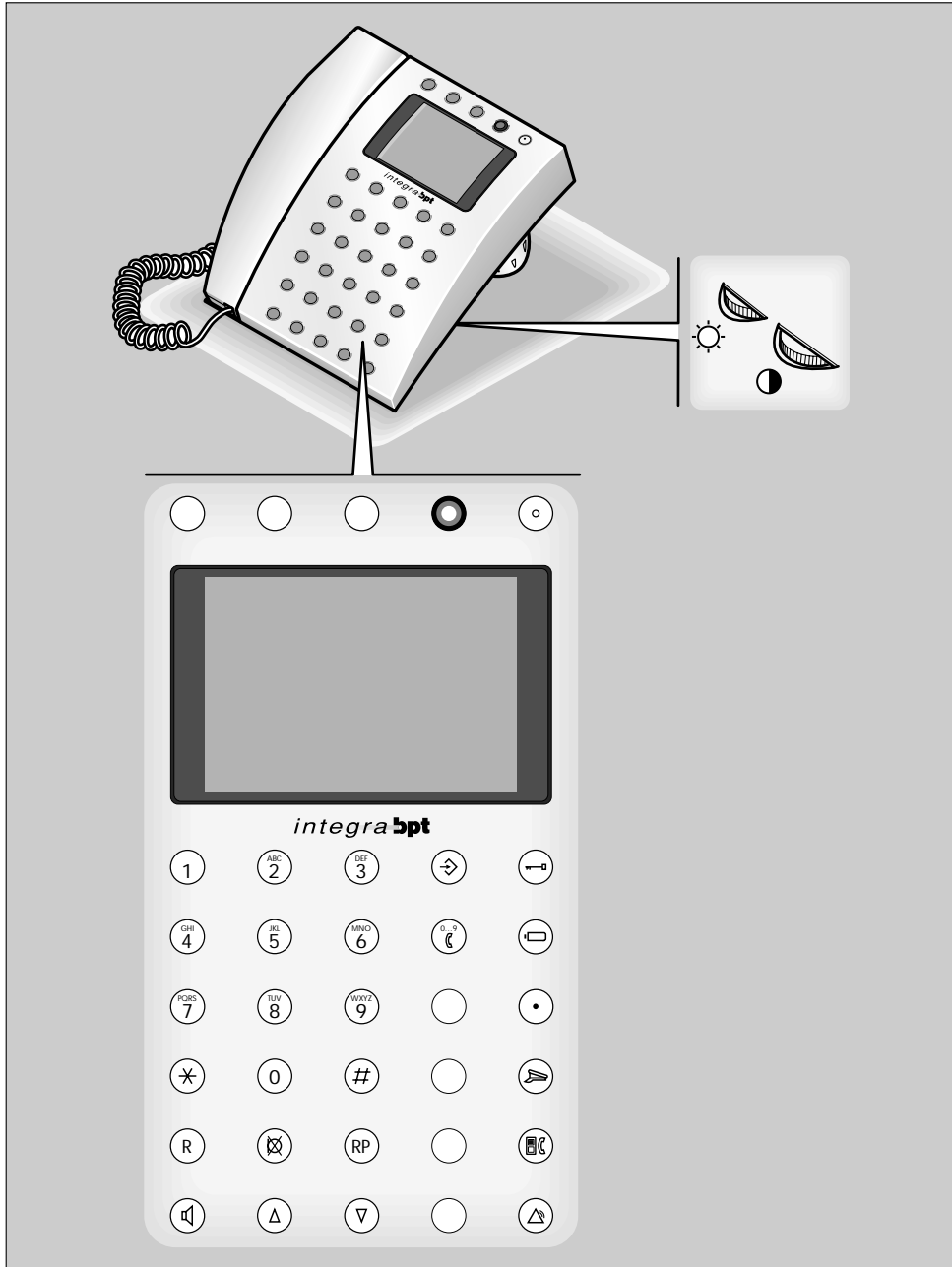







Symboles .....	46	<b>Instructions pour l'utilisateur</b>	
<b>Instructions pour l'installateur</b>		<b>Utilisation .....</b>	<b>57</b>
<b>Conseils .....</b>	<b>48</b>	- Appel .....	57
<b>Généralités .....</b>	<b>49</b>	- Appel à vive-voix (avec récepteur accroché) .....	57
<b>Connexions .....</b>	<b>50</b>	- Touche RP .....	57
<b>Programmation .....</b>	<b>51</b>	- Touche mute .....	57
- Configuration par défaut .....	51	- Touche R (flash) .....	57
- Mémorisation de numéros courts .....	51	- Touche de service .....	58
- Mémorisation d'un numéro pour appel de service .....	52	- Touche numéros courts .....	58
- Programmation de la durée du flash (touche R) .....	52	- Touche de réglage du volume appel à vive-voix .....	58
- Programmation de la durée de la pause .....	53	- Touches fonction portier vidéo .....	58
- Modification du type de sélection .....	53		
- Programmation du volume de la sonnerie .....	54		
- Programmation de la tonalité de la sonnerie .....	54		
- Sélection du type d'appareil auquel le téléphone est raccordé pour les fonctions portier vidéo .....	55		
- Rétablissement de la configuration par défaut .....	55		
<b>Caractéristiques techniques .....</b>	<b>56</b>		

## SYMBOLES

FRANÇAIS



## SYMBOLES

			Clavier téléphone 12 touches standard		Touche de service
					Réglage luminosité
					Réglage contraste mod. IMT/200 et saturation couleur mod. IMTC/200 (*)
				<b>LED</b>	Voyant lumineux rouge du mode vive-voix. Pendant la programmation du téléphone, la LED est allumée.
				Touche R (flash)	
				Touche mute	
				Touche RP (répétition dernier numéro)	
				Touche vive-voix	
				Touche augmentation volume	
			Touche diminution volume		
			Touche de programmation		
			Touche numéros courts		
			Touche ouvre-porte (*)		
			Touche mise en marche automatique/sélection poste extérieur		
			Touche auxiliaire (*)		
			Touche appel concierge (*)		
			Touche de commutation moniteur vidéo/téléphone (*)		

(\*) Touches utilisables si l'appareil est raccordé à des installations de portier vidéo.

---

## CONSEILS

Lire attentivement les instructions contenues dans le présent livret car elles fournissent d'importantes indications concernant la sécurité d'emploi, d'installation et d'entretien.

Après avoir sorti l'appareil de son emballage, contrôler s'il est en bon état.

Les éléments de l'emballage (sachets en plastique, polystyrène expansé, etc.) ne doivent pas être laissés à la portée des enfants car ils pourraient être dangereux.

L'élimination de l'emballage doit être fait conformément aux normes en vigueur.

L'exécution de l'installation doit répondre aux normes de sécurité en vigueur.

**Ne pas faire passer au même endroit les câbles du téléphone et les câbles électriques.**

Installer l'appareil dans un local non poussiéreux, loin de tous appareils pouvant créer des dérangements électriques de haute fréquence comme par ex.: soudeuses, moteurs électriques, fours à micro-ondes, climatiseurs, etc.

Cet appareil ne devra être destiné qu'à l'emploi pour lequel il a été expressément conçu. Toute autre utilisation sera considérée comme impropre et dangereuse.

Le constructeur ne sera pas tenu responsable de tous dommages dérivant d'une utilisation inappropriée, erronée et irraisonnée. Pour toute réparation, s'adresser uniquement à un centre de service après-vente agréé.

Le non-respect des indications ci-dessus peut compromettre la sécurité de l'appareil. L'installateur doit s'assurer que les informations pour l'utilisateur, quand elles sont prévues, soient présentes sur l'appareil.

Tous les appareils constituant l'installation devront être destinés exclusivement à l'emploi pour lequel ils ont été conçus.



---

## GENERALITES

Moniteur avec téléphone IMT/200 (IMTC/200), en version de table, fourni avec cordon d'alimentation multipolaire (1,70 m) et fiche pour le branchement à la prise et avec câble téléphonique (2 m) pour le branchement à la ligne téléphonique urbaine.

Coque en ABS et écran fumé.

L'appareil peut être raccordé, moyennant l'interface IT/200, à des réseaux téléphoniques à décades ou bien à multifréquence et à des installations de portier vidéo système 200.

Il est muni de la fonction vive-voix.

Il est doté de boutons dédiés pour interagir de manière simple avec le système portier vidéo 200 **bpt** au moyen d'une interface téléphonique.

### Fonctions

- Volume note d'appel téléphonique réglable.
- Fonction vive-voix.
- Compatibilité avec système à décades ou multifréquence.
- Commandes pour installations de portier vidéo (pour pouvoir utiliser ces commandes, il est nécessaire d'utiliser l'interface téléphonique **bpt**).
- Il ne nécessite pas d'alimentation supplémentaire.
- Durée de la pause programmable.
- Balayage postes extérieurs et/ou télécaméras supplémentaires.
- Mise en marche automatique.
- Commande ouvre-porte.
- Appel concierge.
- Commandes auxiliaires.



Câble téléphonique

## CONNEXIONS

### Connecteur CN1

Il est utilisé pour effectuer la connexion entre le récepteur et l'appareil (fig. 1).

### Connecteur CN2

Il est utilisé pour effectuer la connexion à la ligne téléphonique urbaine (fig. 1).

**NOTE.** L'appareil ne doit être raccordé que sur des lignes téléphoniques analogiques et non pas sur des lignes digitales ISDN.

### Fonction des bornes de la prise

(voir fig. 2)

1	signal vidéo	} câble coaxial	(1)
2	blindage signal vidéo		
3	signal vidéo	} câble coaxial	
4	blindage signal vidéo		

(1) Si la ligne ne continue pas, connecter une résistance de  $75 \Omega$  (violet-vert-noir-or) entre les bornes 1 et 2.

1	signal vidéo positif	} paire torsadé	(2)
2	signal vidéo négatif		
3	signal vidéo positif	} paire torsadé	
4	signal vidéo négatif		

(2) Si la ligne ne continue pas, connecter deux résistances de  $56 \Omega$  (vert-bleu-noir-or) entre les bornes 1-5 et 2-5.

5	-	} 14 ÷ 17,5V alimentation moniteur
6	+	

7 entrée appel depuis le poste extérieur

8 audio depuis le poste extérieur

FRANÇAIS

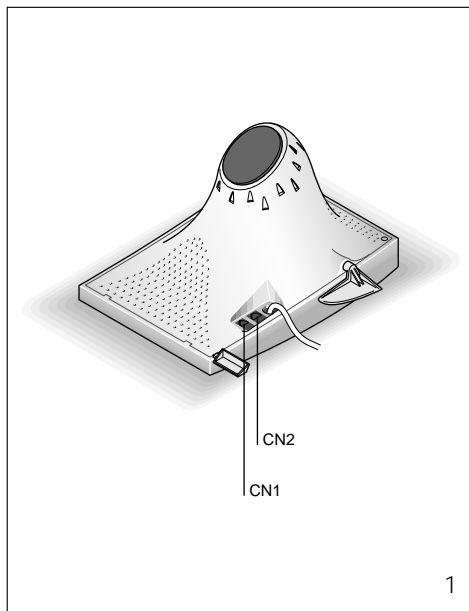

1

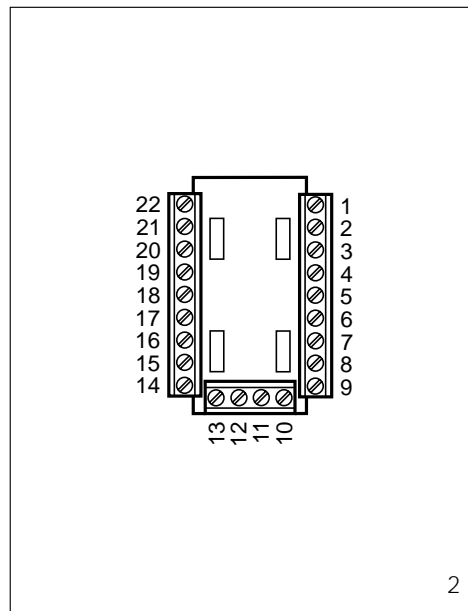

2

## PROGRAMMATION

### Configuration par défaut

- Volume de l'appel: 3 (niveau maximum).
- Note d'appel: mélodie 1.
- Volume vive-voix: 3 (niveau maximum).
- Type de sélection ligne: DTMF.
- Durée pause: 1s.
- Touche R (flash): 100ms.
- Touches fonction portier vidéo: utilisables avec l'interface téléphonique **bpt**.

On peut accéder au mode programmation aussi bien avec le récepteur soulevé qu'en fonction vive-voix.

L'entrée en mode programmation est signalée par le led rouge et par l'absence de signal de ligne.

Pour la programmation de plusieurs fonctions, il n'est pas nécessaire de sortir et de revenir au mode programmation.

*Pendant la programmation, la pression des touches est accompagnée d'un son court, la mémorisation des données d'un son plus long, les erreurs d'un son prolongé.*

**ATTENTION.** Si la programmation est effectuée pendant la connexion à la ligne urbaine, après une minute environ, l'action de dissuasion de la centrale peut déranger la continuation de la programmation.

Dans ce cas, raccrocher le récepteur et recommencer la programmation là où vous l'aviez interrompue.

### Mémorisation de numéros courts



Soulever le récepteur  
ou bien



appuyer sur la touche vive-voix.



Appuyer sur la touche **PROGRAMMATION**.



Appuyer sur la touche **NUMEROS COURTS**.

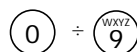

Appuyer sur la touche à laquelle vous associez le numéro de téléphone (0÷9).



Composer le numéro désiré (20 chiffres maxi) (\*).



Appuyer sur la touche **NUMEROS COURTS** pour le mémoriser.



Appuyer sur la touche **PROGRAMMATION**.



Raccrocher  
ou bien



appuyer sur la touche vive-voix.

Répéter cette opération pour mémoriser un autre numéro. Il est possible de mémoriser jusqu'à 10 numéros.

*(\*) Si le téléphone est relié à une centrale de conciergerie, il est nécessaire d'introduire une pause entre le 0 (numéro pour le passage à la ligne urbaine) et le numéro de téléphone.*

*Pour introduire une pause, appuyer sur la touche **RP**: Ex. 0 **RP** 0123 456789.*

*La durée de la pause peut être doublée en appuyant deux fois sur la touche **RP**.*

## PROGRAMMATION

### Mémorisation d'un numéro pour appel de service

Cette programmation peut être utile par exemple pour appeler un numéro de téléphone que vous composez fréquemment ou bien pour éviter de composer des numéros répétitifs comme l'indicatif d'une ville ou celui d'un autre réseau de téléphonie fixe.



Soulever le récepteur  
ou bien



appuyer sur la touche vive-voix.



Appuyer sur la touche **PROGRAMMATION**.



Appuyer sur la touche de **SERVICE**.



Composer le numéro désiré (20 chiffres maxi) (\*).



Appuyer sur la touche de **SERVICE** pour mémoriser.



Appuyer sur la touche **PROGRAMMATION**.



Raccrocher  
ou bien



appuyer sur la touche vive-voix.

### Programmation de la durée du flash (touche R)



Soulever le récepteur  
ou bien



appuyer sur la touche vive-voix.



Appuyer sur la touche **PROGRAMMATION**.



Appuyer sur la touche **R**.

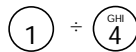

Appuyer sur la chiffre correspondant à la durée que vous souhaitez programmer (1-4) (voir chapitre CARACTERISTIQUES TECHNIQUES).



Appuyer sur **R** pour mémoriser.



Appuyer sur la touche **PROGRAMMATION**.



Raccrocher  
ou bien



appuyer sur la touche vive-voix.

FRANÇAIS

(\*) Si le téléphone est relié à une centrale de conciergerie, il est nécessaire d'introduire une pause entre le 0 (numéro pour le passage à la ligne urbaine) et le numéro de téléphone.

Pour introduire une pause, appuyer sur la touche **RP**: Ex. 0 **RP** 0123 456789.

La durée de la pause peut être doublée en appuyant deux fois sur la touche **RP**.

---

## PROGRAMMATION

### Programmation de la durée de la pause



Soulever le récepteur

ou bien



appuyer sur la touche vive-voix.



Appuyer sur la touche **PROGRAMMATION**.



Appuyer sur la touche **RP**.

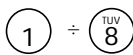

Appuyer sur la chiffre correspondant à la durée que vous souhaitez programmer (**1÷8**) (voir chapitre CARACTERISTIQUES TECHNIQUES).



Appuyer sur **RP** pour mémoriser.



Appuyer sur la touche **PROGRAMMATION**.



Raccrocher

ou bien



appuyer sur la touche vive-voix.

### Modification du type de sélection



Soulever le récepteur

ou bien



appuyer sur la touche vive-voix.



Appuyer sur la touche **PROGRAMMATION**.



Appuyer sur la touche **\*** pour la sélection DTMF.



Appuyer sur la touche **#** pour la sélection A DECADES.



Appuyer sur la touche **PROGRAMMATION**.



Raccrocher

ou bien



appuyer sur la touche vive-voix.

FRANÇAIS

---

## PROGRAMMATION

### Programmation du volume de la sonnerie



Soulever le récepteur  
ou bien



appuyer sur la touche vive-voix.



Appuyer sur la touche **PRO-GRAMMATION**.



Appuyer sur la touche **5**. Le haut-parleur émet la mélodie de la sonnerie avec le niveau de volume précédemment programmé.

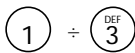

Appuyer sur les touches **1÷3** pour fixer le volume désiré (voir chapitre CARACTERISTIQUES TECHNIQUES).



Appuyer de nouveau sur la touche **5** pour terminer la programmation.



Appuyer sur la touche **PRO-GRAMMATION**.



Raccrocher  
ou bien



appuyer sur la touche vive-voix.

### Programmation de la tonalité de la sonnerie



Soulever le récepteur  
ou bien



appuyer sur la touche vive-voix.



Appuyer sur la touche **PRO-GRAMMATION**.



Appuyer sur la touche **6**. Le haut-parleur émet la mélodie de la sonnerie avec le niveau de volume précédemment programmé.

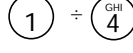

Appuyer sur les touches **1÷4** pour fixer la tonalité désirée (voir chapitre CARACTERISTIQUES TECHNIQUES).



Appuyer de nouveau sur la touche **6** pour terminer la programmation.



Appuyer sur la touche **PRO-GRAMMATION**.



Raccrocher  
ou bien



appuyer sur la touche vive-voix.

---

## PROGRAMMATION

### Sélection du type d'appareil auquel le téléphone est raccordé pour les fonctions PORTIER VIDEO



Soulever le récepteur  
ou bien



appuyer sur la touche vive-voix.



Appuyer sur la touche **PROGRAMMATION**.



Appuyer sur la touche 7.



Appuyer sur la touche 1 si le téléphone est connecté à l'interface téléphonique **bpt**.



Appuyer sur la touche 2 si le téléphone est connecté à une centrale téléphonique PABX **bpt**.



Appuyer sur la touche 7 pour terminer la programmation.



Appuyer sur la touche **PROGRAMMATION**.



Raccrocher  
ou bien



appuyer sur la touche vive-voix.

### Rétablissement de la configuration par défaut



Soulever le récepteur

ou bien



appuyer sur la touche vive-voix.



Appuyer sur la touche **PROGRAMMATION**.



Appuyer deux fois sur la touche 0.



Appuyer sur la touche **PROGRAMMATION**.



Raccrocher

ou bien



appuyer sur la touche vive-voix.

**ATTENTION.** Cette opération efface tous les numéros de téléphone mémorisés.

FRANÇAIS

## CARACTERISTIQUES TECHNIQUES

- Fonctionnement avec vive-voix.
- Possibilité de mémoriser un numéro pour appel de service (20 chiffres maxi).
- Possibilité de mémoriser jusqu'à 10 numéros de téléphone (20 chiffres maxi par numéro).
- Répétition du dernier numéro composé.
- Sonnerie réglable avec 3 niveaux de volume (minimum, moyen, maximum).
- Tonalité de la sonnerie réglable avec 4 mélodies.
- Commandes de portier vidéo (ouvre-porte, appel concierge, commutation portier vidéo/téléphone, auxiliaire/minuterie).
- Résistance entrée appel: 47 k $\Omega$ .
- Signal d'appel: bitonal.
- Durée flash réglable: 1 = 100 ms, 2 = 120 ms, 3 = 300 ms, 4 = 600 ms.
- Durée de la pause réglable de 1 à 8 s: 1 = 1 s, ..., 8 = 8 s.
- Alimentation du téléphone: moyennant ligne urbaine ou interface téléphonique.
- Température de fonctionnement: de 0 °C à +35 °C.
- Humidité relative: 90% sans condensation.

### Moniteur blanc/noir IMT/200

- Alimentation: 14÷17,5 Vcc.
- Consommation: 600 mA maxi (8 mA à repos).
- Tube: CRT 5" (12,5 cm) à 90°.
- Standard CCIR (EIA).
- Impédance d'entrée vidéo:  $\geq 22$  k $\Omega$ .
- Bande passante à -3 dB: 6 MHz.
- Entrée vidéo: 1 Vpp (de 0,5 à 1,5 Vpp) provenant de la ligne coaxiale; V+ 0,6 Vpp, V- 0,6 Vpp (de 0,3 à 0,9 Vpp) provenant de la ligne différentielle (paire torsadé).
- Fréquence horizontale: 15.625 Hz (15.750 Hz EIA).
- Fréquence verticale: 50 Hz (60 Hz EIA).

### Moniteur en couleurs IMTC/200

- Alimentation: 14÷17,5 Vcc.
- Consommation: 500 mA maxi (10 mA à repos).
- Ecran: LCD couleurs 4" à matrice active de 121.108 points.
- Standard PAL.
- Impédance d'entrée vidéo:  $\geq 22$  k $\Omega$ .
- Entrée vidéo: 1 Vpp (de 0,5 à 1,5 Vpp) provenant de la ligne coaxiale; V+ 0,6 Vpp, V- 0,6 Vpp (de 0,3 à 0,9 Vpp) provenant de la ligne différentielle (paire torsadé).
- Bande passante à -3 dB: 6 MHz.

L'appareil est homologué suivant les normes CTR 37 et CTR 38 et satisfait à la norme EN 60950 relative à la sécurité électrique et à la directive 89/336/EEC modifiée par la directive 93/68/EEC relative à la compatibilité électromagnétique.

Approbation européenne délivrée par le TÜV Rheinland Product Safety GmbH

# CE 0197 X



---

## UTILISATION

### Appel



Soulever le récepteur.



Composer le numéro désiré.



En fin de conversation, raccrocher.

### Appel à vive-voix (avec le récepteur accroché)



Appuyer sur la touche vive-voix. La LED rouge s'allume.



Composer le numéro désiré.



En fin de conversation, appuyer de nouveau sur la touche vive-voix.

### Touche RP



Soulever le récepteur  
ou bien



appuyer sur la touche vive-voix.



Appuyer sur la touche RP pour répéter le dernier numéro composé.

**ATTENTION.** La touche RP (répétition du dernier numéro composé) n'est pas utilisable avec les centrales CT/1-6 et CT/2-8.

### Touche MUTE



Appuyer sur la touche **MUTE** si, pendant une conversation téléphonique, vous souhaitez que l'interlocuteur n'écoute pas pour un temps ce que vous êtes en train de dire (microphone, récepteur et haut-parleur sont exclus).



Appuyer de nouveau sur la touche **MUTE** pour rétablir la conversation.

### Touche R (flash)



Cette touche peut être utilisée lorsque le moniteur-vidéo/téléphone est raccordé à une centrale téléphonique. Consulter la notice de la centrale pour connaître l'utilisation de la touche **R**.

## UTILISATION

### Touche de SERVICE

Appel d'un numéro de téléphone que vous composez souvent



Appuyer sur la touche de service.  
Le téléphone se met en mode vive-voix et le numéro mémorisé est composé.

### Appel avec un indicatif



Appuyer sur la touche de service.  
Le téléphone se met en mode vive-voix et l'indicatif mémorisé est composé.



Composer le numéro désiré.



Soulever le récepteur si vous voulez exclure la fonction vive-voix.

FRANÇAIS

### Touche NUMEROS COURTS



Appuyer sur la touche NUMEROS COURTS.

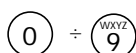

Appuyer sur la touche (0÷9) à laquelle vous avez associé le numéro de téléphone désiré.

### Touches de réglage du volume appel à vive-voix



En utilisant les touches REGLAGE VOLUME pendant la conversation en vive-voix, le volume du haut-parleur peut être augmenté ou diminué.

### Touches fonction PORTIER VIDEO



Auxiliaire/minuterie



Ouvre-porte



Mise en marche poste extérieur



Appel concierge



Commutation moniteur vidéo/téléphone

Ces touches peuvent être utilisées soit avec le téléphone relié à une interface téléphonique **bpt** soit avec un téléphone relié à une centrale PABX **bpt**.

Les touches **OUVRE-PORTE** et **AUXILIAIRE/MINUTERIE** ne sont mises en service qu'après un appel ou une mise en marche automatique.

*NOTE. Les fonctions portier vidéo s'effectuent uniquement lorsque le récepteur est soulevé ou en mode vive-voix.*

*La mise en marche automatique est également possible lorsque le récepteur est accroché.*

**ATTENTION.** La touche **COMMUTATION MONITEUR VIDEO/TELEPHONE** n'est pas utilisable avec les centrales CT/1-6 et CT/2-8.

---

## INDICE





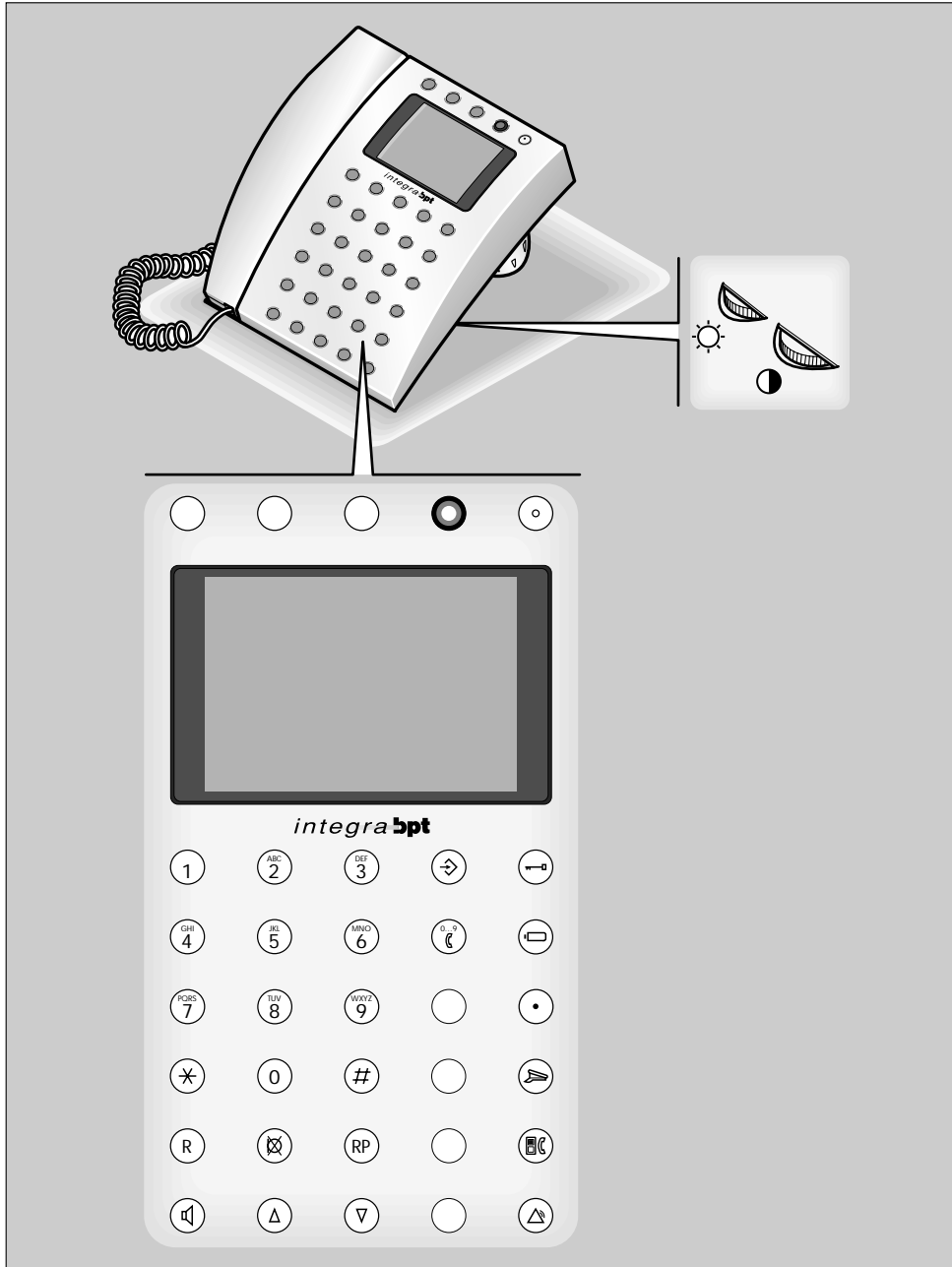























Simbología .....	60	<b>Instrucciones para el usuario</b>	
<b>Instrucciones para el instalador</b>		<b>Modo de empleo .....</b>	<b>71</b>
Advertencias .....	62	- Llamada .....	71
Características generales .....	63	- Llamada manos libres (con auricular colgado) .....	71
Conexiones .....	64	- Tecla RP .....	71
<b>Programación .....</b>	<b>65</b>	- Tecla mute .....	71
- Configuración por defecto .....	65	- Tecla R (flash) .....	71
- Memorización de los números abreviados .....	65	- Tecla de servicio .....	72
- Memorización de un número para llamadas de servicio .....	66	- Tecla números abreviados .....	72
- Programación de la duración del flash (tecla R) .....	66	- Tecla ajuste del volumen en modo manos libres .....	72
- Programación de la duración de la pausa .....	67	- Teclas función videoportero .....	72
- Modificación del tipo de selección ..	67		
- Programación del volumen del timbre .....	68		
- Programación de los tonos del timbre .....	68		
- Selección del tipo de aparato al que el teléfono se conectará para las funciones de videoportero .....	69		
- Reactivación de la configuración por defecto .....	69		
<b>Características técnicas .....</b>	<b>70</b>		

## SIMBOLOGIA



ESPAÑOL

## SIMBOLOGIA

			Teclado telefónico 12 teclas estándar		Tecla de servicio
					Ajuste brillo
					Ajuste contraste mod. IMT/200 y saturación color mod. IMTC/200 (¹)
				<b>LED</b>	Indicador luminoso rojo en modalidad de manos libres. Durante la programación del teléfono el LED permanece encendido.
	Tecla R (flash)				
	Tecla mute				
	Tecla RP (repetición último número)			(¹) Teclas que se pueden utilizar si el aparato está conectado a un equipo de videoportero.	
	Tecla de manos libres				
	Tecla aumento volumen				
	Tecla reducción volumen				
	Tecla de programación				
	Tecla números abreviados				
	Tecla abrepuerta (¹)				
	Tecla autoactivación/selección placa externa				
	Tecla auxiliar (¹)				
	Tecla de llamada conserje (¹)				
	Tecla de conmutación videoportero/teléfono multifunción (¹)				

---

## ADVERTENCIAS

Leer atentamente las advertencias incluidas en este manual ya que proporcionan indicaciones importantes con respecto a la seguridad de utilización, instalación y mantenimiento.

Después de haber desembalado el aparato, comprobar que está en perfectas condiciones.

Los elementos del embalaje (bolsas de plástico, espuma de poliestireno, etc.) no se deben dejar al alcance de los niños ya que representan potenciales fuentes de peligro.

La eliminación de los embalajes se debe realizar de acuerdo con las normas vigentes.

La ejecución de la instalación tiene que respetar las normas de seguridad en vigor.

**No pasar los cables telefónicos por el mismo recorrido que los cables eléctricos.**

Instalar el aparato en ambientes sin polvo, lejos de equipos que puedan generar perturbaciones eléctricas de alta frecuencia como: soldadores, motores eléctricos, hornos microondas, acondicionadores de aire, etc.

Este aparato se tiene que utilizar únicamente para el objetivo para el que ha sido diseñado; cualquier otro tipo de uso se considerará impropio y peligroso.

El fabricante no puede ser considerado responsable por posibles daños derivados de usos impropios, erróneos o irracionales. Si es necesario realizar alguna reparación, habrá que dirigirse únicamente a un centro de asistencia técnica autorizado por el fabricante.

Si no se respetan estas advertencias, se compromete gravemente la seguridad del aparato.

El instalador tendrá que asegurarse de que la información dirigida al usuario, donde esté prevista, se entregue junto a los aparatos.

Todos los aparatos que forman la instalación se tienen que utilizar únicamente para el objetivo para el que han sido diseñados.

---

## CARACTERISTICAS GENERALES

Videoportero-teléfono de sobremesa IMT/200 (IMTC/200) completo de cable multipolar (1,70 m) con clavija para conexión en la toma eléctrica y de cable telefónico (2 m) para el enlace a la línea telefónica urbana.

Caja en ABS y pantalla gris.

El aparato permite la conexión, a través del interfaz telefónico IT/200, a redes telefónicas tanto de tipo decádico como de tipo multifrecuencia e a equipos de videoportero sistema 200.

Dispone de función manos libres.

Cuenta con pulsadores especiales para utilizar de manera sencilla el sistema de videoportero 200 **bpt**, a través del correspondiente interfaz telefónico.

### Funciones

- Ajuste de volumen de la nota de llamada telefónica.
- Función manos libres.
- Compatibilidad con sistema decádico o multifrecuencia.
- Mandos de control para instalaciones de videoportero (para utilizar dichos mandos será necesario el uso del interfaz telefónico **bpt**).
- No necesita alimentador suplementario.
- Se puede programar la duración de la pausa.
- Exploración de placas externas y/o cámaras suplementarias.
- Autoactivación.
- Mando apertura puerta.
- Llamada conserje.
- Mandos auxiliares.



Cable telefónico

## CONEXIONES

### Conector CN1

Se utiliza para realizar la conexión entre el auricular y el aparato (fig. 1).

### Conector CN2

Se utiliza para realizar la conexión del aparato con la línea telefónica urbana (fig. 1).

**NOTA.** El aparato debe conectarse sólo son líneas telefónicas analógicas, no con líneas digitales ISDN.

### Funciones de los bornes de la toma

(ver fig. 2)

- |   |                         |           |       |
|---|-------------------------|-----------|-------|
| 1 | señal de vídeo          | } cable   | ) (1) |
| 2 | pantalla señal de vídeo |           |       |
| 3 | señal de vídeo          | } cable   |       |
| 4 | pantalla señal de vídeo | } coaxial |       |

(1) Si la línea no continúa conectar una resistencia de  $75 \Omega$  (violeta-verde-negro-oro) entre los bornes 1 y 2.

- |   |                         |              |       |
|---|-------------------------|--------------|-------|
| 1 | señal de vídeo positiva | } par        | ) (2) |
| 2 | señal de vídeo negativa |              |       |
| 3 | señal de vídeo positiva | } par        |       |
| 4 | señal de vídeo negativa | } telefónico |       |

(2) Si la línea no continúa conectar dos resistencias de  $56 \Omega$  (verde-azul-negro-oro) entre los bornes 1-5 y 2-5.

- |   |   |  |
|---|---|--|
| 5 | - | } $14 \div 17,5V$ alimentación monitor |
| 6 | + |  |

7 entrada de la llamada desde la placa exterior

8 audio desde la placa exterior

ESPAÑOL

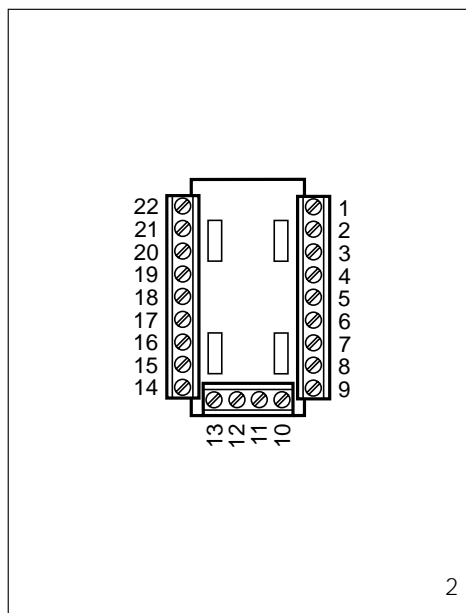
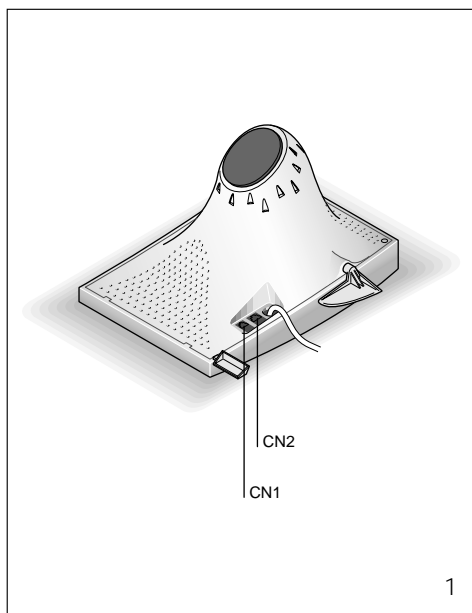



## PROGRAMACION

### Configuración por defecto

- Volumen de llamada: 3 (nivel máximo).
- Nota de llamada: melodía 1.
- Volumen manos libres: 3 (nivel máximo).
- Tipo de selección línea: DTMF.
- Duración pausa: 1 s.
- Pulsador R (flash): 100 ms.
- Teclas función videoportero: a utilizar con interfaz telefónico **bpt**.

Se puede entrar en modo programación, tanto con el microteléfono descolgado como desde la modalidad manos libres.

La entrada en modo programación se indica mediante el encendido del LED rojo y por la ausencia de señal de línea.

Para la programación de más funciones no es necesario salir y volver a entrar en el modo programación.

*Durante la programación, cada vez que se pulse una tecla se oirá un breve sonido, la memorización de los datos producirá un sonido más largo y, los errores un timbre prolongado.*

**ADVERTENCIA.** Si la programación se realiza durante una conexión con la línea urbana, una vez pasado un minuto, la acción de disuasión de la centralita, puede molestar la continuación de la programación.

En este caso se aconseja colgar el microteléfono y seguir con la programación a partir del momento de la interrupción.

### Memorización de los números abreviados



Descolgar el auricular

o



pulsar la tecla manos libres.



Pulsar la tecla **PROGRAMACION**.



Pulsar la tecla **NUMEROS ABREVIADOS**.

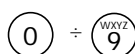

Pulsar la tecla correspondiente al número en el que se quiere memorizar (0÷9).



Marcar el número telefónico deseado (máx. 20 cifras) (¹).



Pulsar la tecla **NUMEROS ABREVIADOS** para memorizar.



Pulsar la tecla **PROGRAMACION**.



Colgar el auricular

o



pulsar la tecla manos libres.

Repetir la operación para memorizar el siguiente número. Se pueden memorizar hasta un máximo de 10 números.

(¹) Si el teléfono está conectado a una centralita, será necesario introducir una pausa entre el 0 (número para obtener la línea urbana) y el número telefónico.

Para introducir una pausa pulsar la tecla **RP**: ej. 0 RP 0123 456789.

La duración de la pausa se puede duplicar si se pulsa dos veces la tecla **RP**.

## PROGRAMACION

### Memorización de un número para llamada de servicio

Este tipo de programación puede ser útil, por ejemplo, para llamar a un número telefónico de uso frecuente, o para evitar marcar números repetitivos como el prefijo urbano o el prefijo de otra red de telefonía fija.



Descolgar el auricular

o



pulsar la tecla manos libres.



Pulsar la tecla **PROGRAMACION**.



Pulsar la tecla **SERVICIO**.



Marcar el número telefónico deseado (máx. 20 cifras) (\*).



Pulsar la tecla **SERVICIO** para memorizar.



Pulsar la tecla **PROGRAMACION**.



Colgar el auricular

o



pulsar la tecla manos libres.

ESPAÑOL

(\* Si el teléfono está conectado a una centralita, será necesario introducir una pausa entre el 0 (número para obtener la línea urbana) y el número telefónico.

Para introducir una pausa pulsar la tecla **RP**: ej. 0 RP 0123 456789.

La duración de la pausa se puede duplicar si se pulsa dos veces la tecla **RP**.

### Programación de la duración del flash (tecla R)



Descolgar el auricular

o



pulsar la tecla manos libres.



Pulsar la tecla **PROGRAMACION**.



Pulsar la tecla **R**.

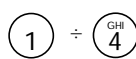

Pulsar la tecla correspondiente al número de la duración que se desea memorizar (1÷4) (véase capítulo **CARACTERISTICAS TECNICAS**).



Pulsar la tecla **R** para memorizar.



Pulsar la tecla **PROGRAMACION**.



Colgar el auricular

o



pulsar la tecla manos libres.

---

## PROGRAMACION

### Programación de la duración de la pausa



Descolgar el auricular

o



pulsar la tecla manos libres.



Pulsar la tecla **PROGRAMACION**.



Pulsar la tecla **RP**.

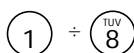

Pulsar la tecla correspondiente al número de la duración que se desea memorizar (1-8) (véase capítulo CARACTERISTICAS TECNICAS).



Pulsar la tecla **RP** para memorizar.



Pulsar la tecla **PROGRAMACION**.



Colgar el auricular

o



pulsar la tecla manos libres.

### Modificación del tipo de selección



Descolgar el auricular

o



pulsar la tecla manos libres.



Pulsar la tecla **PROGRAMACION**.



Pulsar la tecla **\*** para la selección DTMF.



Pulsar la tecla **#** para la selección DECADICA.



Pulsar la tecla **PROGRAMACION**.



Colgar el auricular

o



pulsar la tecla manos libres.

---

## PROGRAMACION

### Programación del volumen del timbre



Descolgar el auricular

o



pulsar la tecla manos libres.



Pulsar la tecla **PROGRAMACION**.



Pulsar la tecla **5**. Empezará a sonar la melodía del timbre con el volumen anteriormente programado.

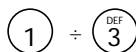

Pulsar las teclas **1÷3** para fijar el volumen deseado (véase capítulo CARACTERISTICAS TECNICAS).



Volver a pulsar la tecla **5** para finalizar la programación.



Pulsar la tecla **PROGRAMACION**.



Colgar el auricular

o



pulsar la tecla manos libres.

### Programación de los tonos del timbre



Descolgar el auricular

o



pulsar la tecla manos libres.



Pulsar la tecla **PROGRAMACION**.



Pulsar la tecla **6**. Empezará a sonar la melodía del timbre con el volumen anteriormente programado.

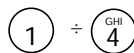

Pulsar las teclas **1÷4** para fijar el tono deseado (véase capítulo CARACTERISTICAS TECNICAS).



Volver a pulsar la tecla **6** para finalizar la programación.



Pulsar la tecla **PROGRAMACION**.



Colgar el auricular

o



pulsar la tecla manos libres.

## PROGRAMACION

### Selección del tipo de aparato al que el teléfono se conectará para las funciones de VIDEOPORTERO



Descolgar el auricular

o



pulsar la tecla manos libres.



Pulsar la tecla **PROGRAMACION**.



Pulsar la tecla 7.



Pulsar la tecla **1** si el teléfono está conectado con el interfaz telefónico **bpt**.



Pulsar la tecla **2** si el teléfono está conectado con una centralita telefónica PABX **bpt**.



Volver a pulsar la tecla 7 para finalizar la programación.



Pulsar la tecla **PROGRAMACION**.



Colgar el auricular

o



pulsar la tecla manos libres.

### Reactivación de la configuración por defecto



Descolgar el auricular

o



pulsar la tecla manos libres.



Pulsar la tecla **PROGRAMACION**.



Pulsar dos veces la tecla 0.



Pulsar la tecla **PROGRAMACION**.



Colgar el auricular

o



pulsar la tecla manos libres.

**ATENCION.** Con esta operación se cancelan todos los números telefónicos memorizados.

---

## CARACTERISTICAS TECNICAS

- Función manos libres.
- Posibilidad de memorizar un número para llamada de servicio (máx. 20 cifras).
- Posibilidad de memorizar hasta 10 números telefónicos (máx. 20 cifras por número).
- Repetición del último número marcado.
- Ajuste de volumen de timbre de llamada a 3 niveles (mínimo, medio, máximo).
- Ajuste de tono de timbre de llamada: 4 melodías.
- Mandos de control videoportero (abrepuerta, llamada conserje, conmutación videoportero/teléfono multifunción, auxiliar/luz escalera).
- Resistencia entrada llamada: 47 k $\Omega$ .
- Señal de llamada: bitonal.
- Ajuste duración del flash: 1 = 100 ms, 2 = 120 ms, 3 = 300 ms, 4 = 600 ms.
- Ajuste duración pausa de 1 a 8 s: 1 = 1 s, ..., 8 = 8 s.
- Alimentación teléfono: de la línea urbana o del interfaz telefónico.
- Temperatura de funcionamiento: de 0 °C a +35 °C.
- Humedad relativa: 90% sin condensación.

### Monitor b/n IMT/200

- Alimentação: 14÷17,5 Vcc.
- Absorción: 600 mA max. (8 mA en reposo).
- Cinescopio: CRT 5" (12,5 cm) a 90°.
- Estándar CCIR (EIA).
- Impedancia de entrada vídeo:  $\geq 22$  k $\Omega$ .
- Banda pasante a -3 dB: 6 MHz.
- Entrada vídeo: 1 Vpp (de 0,5 a 1,5 Vpp) de línea coaxial; V+ 0,6 Vpp, V- 0,6 Vpp (de 0,3 a 0,9 Vpp) de línea diferencial (par telefónico).
- Frecuencia horizontal: 15.625 Hz (15.750 Hz EIA).
- Frecuencia vertical: 50 Hz (60 Hz EIA).

### Monitor color IMTC/200

- Alimentação: 14÷17,5Vcc.
- Absorción: 500 mA max. (10 mA en reposo).
- Display: LCD de colores, 4" de matriz activa de 121.108 puntos.
- Estándar PAL.
- Impedancia de entrada vídeo:  $\geq 22$  k $\Omega$ .
- Banda pasante a -3 dB: 5 MHz.
- Entrada vídeo: 1 Vpp (de 0,5 a 1,5 Vpp) de línea coaxial; V+ 0,6 Vpp, V- 0,6 Vpp (de 0,3 a 0,9 Vpp) de línea diferencial (par telefónico).

El aparato está homologado según las normas CTR 37 y CTR 38 y cumple con la norma EN 60950, relativa a la seguridad eléctrica y con la directiva 89/336/EEC modificada con la 93/68/EEC, relativas a la compatibilidad electromagnética.

Aprobación europea expedida por TÜV Rheinland Product Safety GmbH

# CE 0197 X

---

## MODO DE EMPLEO

### Llamada



Descolgar el auricular.



Marcar el número deseado.



Una vez terminada la conversación, colgar el auricular.

### Tecla MUTE



Pulsar la tecla **MUTE** si durante la conversación telefónica se desea impedir, temporalmente, que el interlocutor escuche (micrófono, auricular y altavoz se desactivan).



Pulsar de nuevo la tecla **MUTE** para retomar la conversación.

### Llamada manos libres (con auricular colgado)



Pulsar la tecla manos libres. Se encenderá el LED rojo.



Marcar el número deseado.



Una vez terminada la conversación, volver a pulsar la tecla manos libres.

### Tecla R (flash)



Esta tecla se puede utilizar cuando el monitor con teléfono está conectado a una centralita telefónica.

Consultar el manual de instrucciones para conocer la utilización de la tecla **R**.

### Tecla RP



Descolgar el auricular

o



pulsar la tecla manos libres.



Pulsar la tecla **RP** para que repita el último número marcado.

**ATENCIÓN.** La tecla RP (repetición del último número marcado) no es utilizable con las centralitas CT/1-6 y CT/2-8.

## MODO DE EMPLEO

### Tecla de SERVICIO

Llamada a un número telefónico de uso frecuente



Pulsar la tecla **SERVICIO**. El teléfono se activa en modalidad manos libres y se marca automáticamente el número memorizado.

### Llamada con prefijo



Pulsar la tecla **SERVICIO**. El teléfono se activa en modalidad manos libres y se marca automáticamente el prefijo memorizado.



Marcar el número deseado.



Descolgar el auricular si se desea desactivar la función manos libres.

### Tecla NUMEROS ABREVIADOS



Pulsar la tecla **NUMEROS ABREVIADOS**.

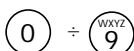

Pulsar la tecla (0÷9) que corresponde al número telefónico deseado.

ESPAÑOL

### Tecla ajuste del volumen en modo manos libres



Si se utilizan las teclas **AJUSTE DE VOLUMEN** durante la conversación en función manos libres, el volumen del altavoz se puede aumentar o disminuir.

### Teclas función VIDEOPORTERO



Auxiliar/Luz escalera



Abrepuerta



Activación placa esterna



Llamada conserje



Conmutación videoportero/teléfono multifunción

Estas teclas se pueden utilizar tanto si el teléfono está conectado a una interfaz telefónico **bpt**, como si el teléfono está conectado a una centralita PABX **bpt**. Los botones **ABREPUERTA** y **AUXILIAR/LUZ ESCALERAS** están habilitados sólo en caso de llamada o de autoactivación.

*NOTA. Las funciones de videoportero están permitidas sólo con el microteléfono descolgado o en modalidad manos libres. La autoactivación es posible también con el auricular colgado.*

**ATENCIÓN.** La tecla **CONMUTACION VIDEOPORTERO/TELEFONO MULTIFUNCION** no es utilizable con las centralitas CT/1-6 y CT/2-8.



---

## INDICE

Simbologia .....	74	<b>Instruções para o utente</b>	
<b>Instruções para o instalador</b>		<b>Utilização .....</b>	<b>.85</b>
Advertências .....	76	- Chamada .....	.85
Generalidade .....	77	- Chamada viva-voz	
Ligações .....	78	(com auscultador no suporte) .....	.85
Programação .....	79	- Tecla RP .....	.85
- Configuração de default .....	79	- Tecla mute .....	.85
- Memorização dos números breves ..	79	- Tecla R (flash) .....	.85
- Memorização de um número		- Tecla de serviço .....	.86
para chamada de serviço .....	80	- Tecla números breves .....	.86
- Programação da duração		- Teclas regulação	
do flash (tecla R) .....	80	do volume em viva voz .....	.86
- Programação da duração		- Tecla função videoproteiro .....	.86
da pausa .....	81		
- Modificação do tipo de selecção ..	81		
- Programação do volume			
do dispositivo acústico .....	82		
- Programação da tonalidade			
do dispositivo acústico .....	82		
- Selecção do tipo de aparelhagem			
com o qual o telefone está ligado			
para as funções videoproteiro .....	83		
- Restabelecimento da configuração			
de default .....	83		
Características técnicas .....	84		



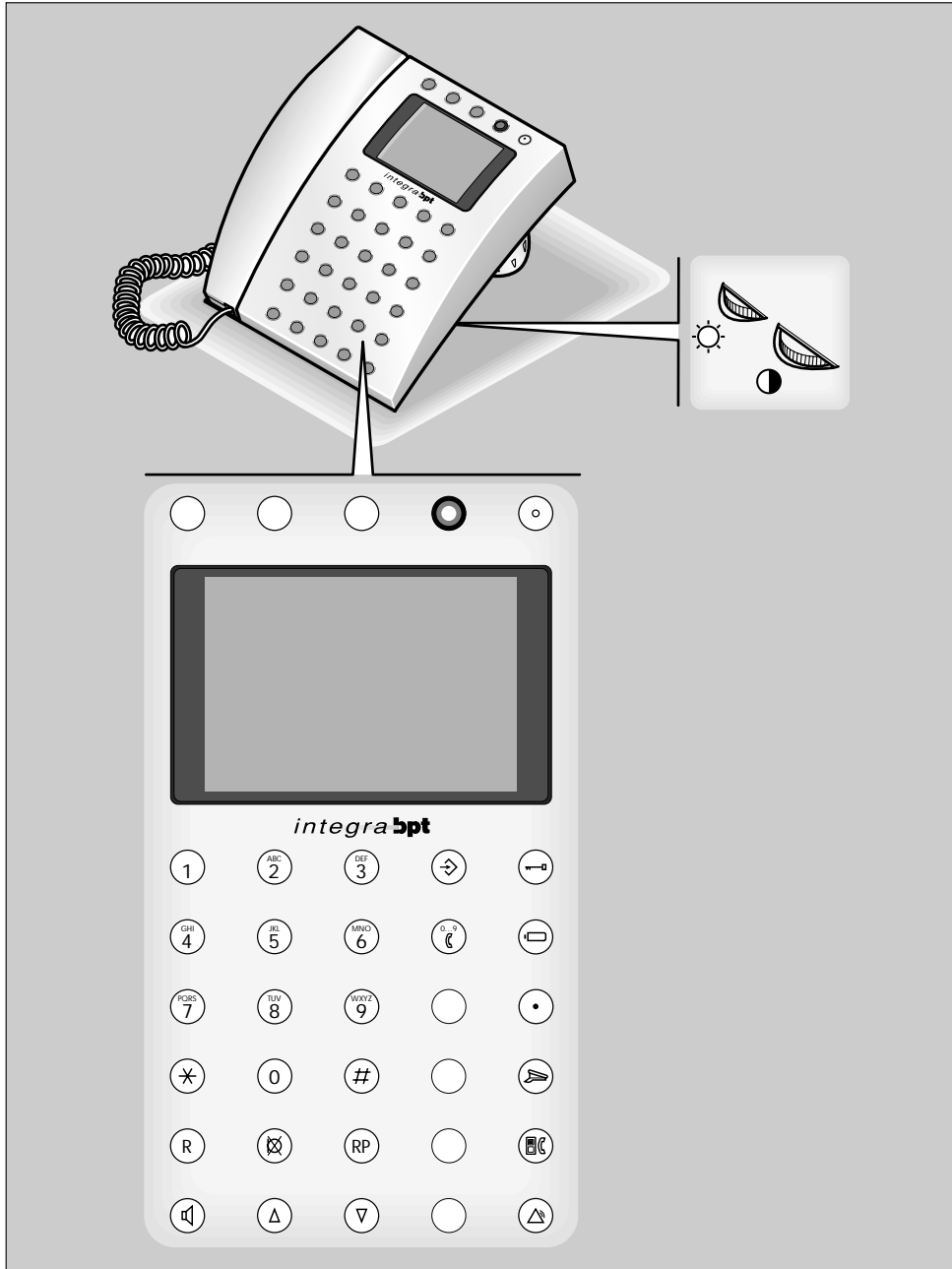

























## SIMBOLOGIA



PORTUGUÊS

---

## SIMBOLOGIA

			Teclado telefónico 12 teclas standard		Tecla de serviço
					Regulação da luminosidade
					Regulação do contraste mod. IMT/200 e saturação da cor mod. IMTC/200 (*)
				<b>LED</b>	Sinalizador luminoso vermelho de modalidade viva voz. Durante a programação do telefone o LED está aceso.
	Tecla R (flash)			(*) Teclas utilizáveis se o aparelho está ligado a instalações videoproteiro.	
	Tecla mute				
	Tecla RP (repetição do último número)				
	Tecla viva voz				
	Tecla incremento volume				
	Tecla decremento volume				
	Tecla de programação				
	Tecla números breves				
	Tecla abertura porta (*)				
	Tecla de inserção automática/ selecção da placa botoneira				
	Tecla auxiliar (*)				
	Tecla de chamada porteiro (*)				
	Tecla de comutação videoproteiro/telefone (*)				

---

## ADVERTÊNCIAS

Ler com atenção as advertências contidas no seguinte manual porque fornecem importantes indicações que dizem respeito à segurança do uso, da instalação e manutenção.

Depois de ter tirado a embalagem certificar-se da integridade do aparelho.

Os elementos da embalagem (sacos de plástica, poliestireno expando, etc.) não devem ser deixados ao alcance das crianças porque constituem potenciais fontes de perigo.

A eliminação das embalagens deve ser efectuada no respeito das normas vigentes.

A execução da instalação deve corresponder às normas de segurança vigentes.

**Não passar os cabos telefónicos em percursos comuns aqueles dos cabos eléctricos.**

Instalar o aparelho em ambientes não poeireiros, longe de aparelhagens que possam gerar distúrbios eléctricos de alta frequência, tais como soldadoras, motores eléctricos, fornos a micro-ondas, condicionadores de ar, etc.

Este aparelho deverá ser destinado unicamente ao uso para o qual foi expressamente concebido; qualquer uso diverso é considerado impróprio e perigoso.

O fabricante não pode ser considerado responsável por eventuais danos que derivam de usos impróprios, erróneos e irracionais.

Para a eventual reparação dirigir-se somente a um centro de assistência técnica autorizado pelo fabricante.

O não respeito de quanto acima pode comprometer a segurança do aparelho.

O instalador deve certificar-se que as informações para o utente, onde previsto, estejam presentes sobre os aparelhos.

Todos os aparelhos que fazem parte do equipamento devem ser destinados exclusivamente para o uso para os quais foram concebidos.

---

## GENERALIDADE

Videoproteiro automático com telefone de mesa IMT/200 (IMTC/200) completo de cabo multipolar (1,70 m) com ficha para a ligação à tomada e de cabo telefónico (2 m) para a ligação à linha telefónica urbana.

Caixa em ABS e ecrã de vidro fumado.

O aparelho permite a conexão, através da interface telefónica IT/200, a redes telefónicas seja de tipo decádico, quer seja de tipo multifrequência e a instalação videoproteiro sistema 200.

Está dotado da função viva voz.

Está dotado de botões dedicados para inter-agir em modo simples com o sistema videoproteiro 200 **bpt** através da oportuna interface telefónica.

### Funções

- Volume nota de chamada telefónica regulável.
- Função viva-voz.
- Compatibilidade com o sistema "decádico" ou multifrequência.
- Comandos para instalações videoproteiro (para a actuação destes comandos é necessário o uso da interface telefónica **bpt**).
- Não necessita de alimentador suplementar.
- Duração da pausa programável.
- Escanção das placas botoneiras e/ou câmaras de vídeo suplementares.
- Inserção automática.
- Comando abertura porta.
- Chamada proteiro.
- Comandos auxiliares.



Cabo telefónico

## LIGAÇÕES

### Conector CN1

É utilizado para efectuar a ligação entre o auscultador e o aparelho (fig. 1).

### Conector CN2

É utilizado para efectuar a ligação do aparelho à linha telefónica (fig. 1).

NOTA. O aparelho só deve ser ligado a linhas telefónicas analógicas, não a linhas digitais ISDN.

### Função dos bornes da tomada

(ver fig. 2)

- |   |                   |        |     |
|---|-------------------|--------|-----|
| 1 | sinal vídeo       | } cabo | (1) |
| 2 | massa sinal vídeo |        |     |
| 3 | sinal vídeo       | } cabo |     |
| 4 | massa sinal vídeo |        |     |

(1) Se a linha coaxial não avança, ligar uma resistência de 75 Ω (roxo, verde, preto, ouro) entre os bornes 1 e 2.

- |   |                      |       |     |
|---|----------------------|-------|-----|
| 1 | sinal vídeo positivo | } par | (2) |
| 2 | sinal vídeo negativo |       |     |
| 3 | sinal vídeo positivo | } par |     |
| 4 | sinal vídeo negativo |       |     |

(2) Se a linha coaxial não avança, ligar dois resistências de 75 Ω (verde, azul, preto, ouro) entre os bornes 1-5 e 2-5.

- |   |                                    |                                  |
|---|------------------------------------|----------------------------------|
| 5 | -                                  | } 14 ÷ 17,5V alimentação monitor |
| 6 | +                                  |                                  |
| 7 | entrada chamada da placa botoneira |                                  |
| 8 | audio da placa botoneira           |                                  |

PORTUGUÊS

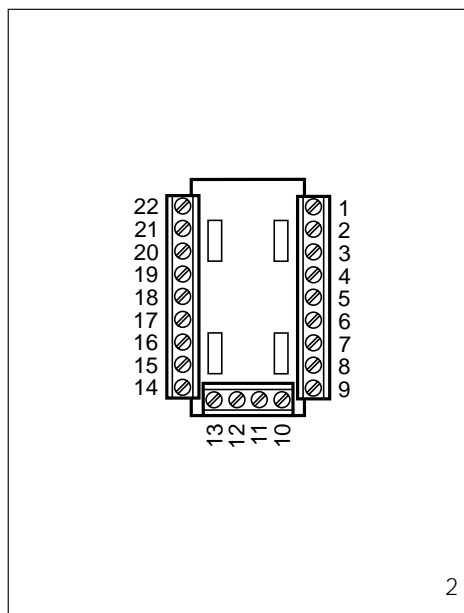
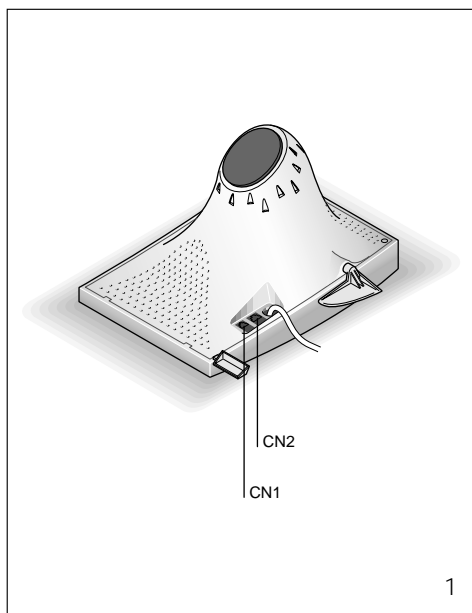

## PROGRAMAÇÃO

### Configuração de default

- Volume de chamada: 3 (nível máximo).
- Nota de chamada: melodia 1.
- Volume viva voz: 3 (nível máximo).
- Tipo de selecção linha: DTMF.
- Duração da pausa: 1 s.
- Botão R (flash): 100 ms.
- Teclas função videoporteiro: utilizáveis com a interface telefónica **bpt**.

Pode-se entrar no modo programação, seja com auscultador levantado que na modalidade viva voz.

A entrada na programação é sinalizada pelo LED vermelho e pela ausência do sinal de linha.

Para a programação de outras funções não é necessário sair e tornar a entrar da modalidade programação.

*Durante a programação a pressão das teclas é acompanhada por um som breve, a memorização dos dados por um som mais longo, os erros por um som prolongado.*

**ADVERTÊNCIA.** Se a programação for efectuada durante a ligação com a linha urbana, cerca de um minuto depois a acção de dissuasão da central pode perturbar a continuação da programação.

Neste caso tornar a colocar o auscultador no suporte e retomar a programação do ponto interrompido.

### Memorização dos números breves



Levantar o auscultador  
ou então



premir a tecla viva voz.



Premir a tecla **PROGRA-  
MAÇÃO**.



Premir a tecla **NUMEROS  
BREVES**.

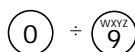

Premir a tecla com a qual é  
associado o número telefó-  
nico (0÷9).



Marcar o número desejado  
(máximo 20 cifras) (\*).



Premir a tecla **NUMEROS  
BREVES** para memorizar.



Premir a tecla **PROGRA-  
MAÇÃO**.



Tornar a colocar no suporte  
o auscultador

ou então



premir a tecla viva voz.

Repetir a operação para memorizar o número sucessivo. Podem-se memorizar até 10 números.

*(\*) Se o telefone está ligado a uma central é necessário inserir uma pausa entre o 0 (número para a passagem à linha urbana) e o número telefónico.*

*Para inserir uma pausa premir a tecla **RP**:  
es. 0 **RP** 0123 456789.*

*A duração da pausa pode ser duplicada  
premindo duas vezes a tecla **RP**.*

## PROGRAMAÇÃO

### Memorização de um número para chamada de serviço

Esta programação pode ser útil, por exemplo, para chamar um número telefónico de uso frequente, ou então para evitar de marcar números repetitivos, tais como o indicativo urbano ou de outra rede de telefonia fixa.



Levantar o auscultador  
ou então



premir a tecla viva voz.



Premir a tecla **PROGRAMAÇÃO**.



Premir a tecla de **SERVIÇO**.



Marcar o número desejado (máximo 20 cifras) (\*).



Premir a tecla de **SERVIÇO** para memorizar.



Premir a tecla **PROGRAMAÇÃO**.



Tornar a colocar no suporte o auscultador  
ou então



premir a tecla viva voz.

### Programação da duração do flash (tecla R)



Levantar o auscultador  
ou então



premir a tecla viva voz.



Premir a tecla **PROGRAMAÇÃO**.



Premir a tecla **R**.

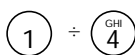

Premir o número relativo à duração que se entende programar (**1÷4**) (ver capítulo **CARACTERÍSTICAS TÉCNICAS**).



Premir **R** para memorizar.



Premir a tecla **PROGRAMAÇÃO**.



Tornar a colocar no suporte o auscultador  
ou então



premir a tecla viva voz.

(\*) Se o telefone está ligado a uma central é necessário inserir uma pausa entre o 0 (número para a passagem à linha urbana) e o número telefónico.

Para inserir uma pausa premir a tecla **RP**:  
es. 0 **RP** 0123 456789.

A duração da pausa pode ser duplicada premindo duas vezes a tecla **RP**.



---

## PROGRAMAÇÃO

### Programação da duração da pausa



Levantar o auscultador  
ou então



premir a tecla viva voz.



Premir a tecla **PROGRA-  
MAÇÃO**.



Premir a tecla **RP**.

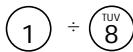

Premir o número relativo à  
duração que se entende pro-  
gramar (1÷8) (ver capítulo  
CARACTERISTICAS TECNI-  
CAS).



Premir **RP** para memorizar.



Premir a tecla **PROGRA-  
MAÇÃO**.



Tornar a colocar no suporte  
o auscultador

ou então



premir a tecla viva voz.

### Modificação do tipo de selecção



Levantar o auscultador  
ou então



premir a tecla viva voz.



Premir a tecla **PROGRA-  
MAÇÃO**.



Premir a tecla **\*** para a  
selecção DTMF.



Premir a tecla **#** para a  
selecção DECADICA.



Premir a tecla **PROGRA-  
MAÇÃO**.



Tornar a colocar no suporte  
o auscultador

ou então



premir a tecla viva voz.

---

## PROGRAMAÇÃO

### Programação do volume do dispositivo acústico



Levantar o auscultador ou então



premir a tecla viva voz.



Premir a tecla **PROGRAMAÇÃO**.



Premir a tecla **5**. É emitida pelo antifalante a melodia do dispositivo acústico com o nível do volume precedentemente programado.

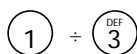

Premir as teclas **1÷3** para estabelecer o volume desejado (ver capítulo CARACTERÍSTICAS TÉCNICAS).



Premir novamente a tecla **5** para terminar a programação.



Premir a tecla **PROGRAMAÇÃO**.



Tornar a colocar no suporte o auscultador ou então



premir a tecla viva voz.

### Programação da tonalidade do dispositivo acústico



Levantar o auscultador ou então



premir a tecla viva voz.



Premir a tecla **PROGRAMAÇÃO**.



Premir a tecla **6**. É emitida pelo antifalante a melodia do dispositivo acústico com o nível do volume precedentemente programado.

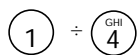

Premir as teclas **1÷4** para estabelecer a tonalidade desejada (ver capítulo CARACTERÍSTICAS TÉCNICAS).



Premir novamente a tecla **6** para terminar a programação.



Premir a tecla **PROGRAMAÇÃO**.



Tornar a colocar no suporte o auscultador ou então



premir a tecla viva voz.

---

## PROGRAMAÇÃO

### Seleção do tipo de aparelhagem com o qual o telefone está ligado para as funções VIDEOPORTEIRO



Levantar o auscultador ou então



premir a tecla viva voz.



Premir a tecla **PROGRA-MAÇÃO**.



Premir a tecla **7**.



Premir a tecla **1** se o telefone está ligado com a interface telefónica **bpt**.



Premir a tecla **2** se o telefone está ligado com uma central telefónica PABX **bpt**.



Premir a tecla **7** para terminar a programação.



Premir a tecla **PROGRA-MAÇÃO**.



Tornar a colocar no suporte o auscultador ou então



premir a tecla viva voz.

### Restabelecimento da configuração de default



Levantar o auscultador ou então



premir a tecla viva voz.



Premir a tecla **PROGRA-MAÇÃO**.



Premir duas vezes a tecla **0**.



Premir a tecla **PROGRA-MAÇÃO**.



Tornar a colocar no suporte o auscultador ou então



premir a tecla viva voz.

**ATENÇÃO.** Com esta operação se anulam todos os números telefónicos memorizados.

---

## CARACTERISTICAS TECNICAS

- Funcionamento viva voz.
- Possibilidade de memorizar um número para chamada de serviço (20 cifras máx.).
- Possibilidade de memorizar até 10 números telefónicos (20 cifras máx. por número).
- Repetição do último número marcado.
- Dispositivo acústico regulável em volume com 3 níveis (mínimo, médio, máximo).
- Dispositivo acústico regulável na tonalidade com 4 melodias.
- Comandos videoporteiro (abertura da porta, chamada porteiro, comutação videoporteiro/telefone, auxiliar/luz escadas).
- Resistência entrada da chamada: 47 k $\Omega$ .
- Sinal de chamada: de dois tons.
- Duração flash regulável: 1 = 100 ms, 2 = 120 ms, 3 = 300 ms, 4 = 600 ms.
- Duração da pausa regulável desde 1 até 8 s: 1 = 1 s, ..., 8 = 8 s.
- Alimentação telefone: da linha urbana ou da interface telefónica.
- Temperatura de funcionamento: desde 0 °C até +35 °C.
- Humidade relativa: 90% sem condensação.

### Monitor b/p IMT/200

- Alimentação: 14÷17,5 Vcc.
- Consumo: 600 mA max. (8 mA em descanso).
- Cinescópico: CRT 5" (12,5 cm) a 90°.
- Standard vídeo: CCIR (EIA).
- Impedância de entrada vídeo:  $\geq 22 \Omega$ .
- Banda passante a -3 dB: 6 MHz.
- Entrada vídeo: 1 Vpp (de 0,5 a 1,5 Vpp) de linha coaxial; V+ 0,6 Vpp, V- 0,6 Vpp (de 0,3 a 0,9 Vpp) de linha diferencial (par telefónico).
- Frequência horizontal: 15.625 Hz (15.750 Hz EIA).
- Frequência vertical: 50 Hz (60 Hz EIA).

### Monitor a cores IMTC/200

- Alimentação: 14÷17,5 Vcc.
- Consumo: 500 mA max. (10 mA em descanso).
- Display: LCD cor 4" com matriz activa de 121.108 pontos.
- Standard vídeo: PAL.
- Impedância de entrada vídeo:  $\geq 22 k\Omega$ .
- Banda passante a -3 dB: 6 MHz.
- Entrada vídeo: 1 Vpp (de 0,5 a 1,5 Vpp) de linha coaxial; V+ 0,6 Vpp, V- 0,6 Vpp (de 0,3 a 0,9 Vpp) de linha diferencial (par telefónico).

O aparelho foi homologado segundo as normas CTR 37 e CTR 38 e satisfaz a norma EN 60950, relativa à segurança eléctrica, e a directiva 89/336/EEC modificada com 93/68/EEC, relativas à compatibilidade electromagnética.

Aprovação europeia passada pelo TÜV Rheinland Product Safety GmbH

# CE 0197 X

---

## UTILIZAÇÃO

### Chamada



Levantar o auscultador.



Marcar o número desejado.



Ao fim da conversação, tornar a colocar o auscultador no suporte.

### Chamada viva voz (com auscultador no suporte)



Premir a tecla viva voz.



Marcar o número desejado.



Ao fim da conversação, tornar a premir a tecla viva voz.

### Tecla RP



Levantar o auscultador ou então



premir a tecla viva voz.



Premir a tecla **RP** para efectuar a repetição do último número marcado.

**ATENÇÃO.** A tecla **RP** (repetição do último número marcado) não é utilizável com as centrais CT/1-6 e CT/2-8.

### Tecla MUTE



Premir a tecla **MUTE** se durante uma conversação telefónica se deseja impedir temporariamente a audição por parte do interlocutor (microfone, auscultador e altifalante podem ser desactivados).



Premir novamente a tecla **MUTE** para restabelecer a conversação.

### Tecla R (flash)



Esta tecla pode ser utilizada quando o telefone está ligado a uma central telefónica. Consultar o manual de instruções da central utilizada para conhecer a utilização da tecla **R**.

## UTILIZAÇÃO

### Tecla de SERVIÇO

Chamada a um número telefónico de utilização frequente



Premir a tecla **SERVIÇO**. O telefone se coloca em modalidade viva voz e é enviado o número memorizado.

Chamada através do indicativo



Premir a tecla **SERVIÇO**. O telefone se coloca em modalidade viva voz e é enviado o indicativo memorizado.



Marcar o número desejado.



Levantar o auscultador se se deseja excluir a função viva voz.

### Tecla NUMEROS BREVES



Premir a tecla **NUMEROS BREVES**.

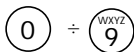

Premir a tecla (0÷9) à qual foi associado o número telefónico desejado.

Tecla regulação do volume em viva voz



Utilizando as teclas **REGULAÇÃO VOLUME** durante a conversação a viva voz, o volume do altifalante pode ser aumentado ou diminuído.

### Teclas função VIDEOPORTEIRO



Auxiliar/Luz escadas



Abertura porta



Inserção placa botoneira



Chamada porteiro



Comutação videoporteiro/telefone

Estas teclas podem ser utilizadas seja com telefone ligado a uma interface telefónica **bpt** seja com um telefone ligado a uma central PABX **bpt**.

As teclas de **ABERTURA DA PORTA** e **AUXILIAR/LUZ DAS ESCADAS** se habilitam só a seguir a uma chamada ou inserção automática.

*NOTA.* As funções telefone videoporteiro são consentidas só com o auscultador levantado ou na modalidade viva voz.

É possível a inserção automática mesmo com o auscultador enganchado.

**ATENÇÃO.** A tecla **COMUTAÇÃO VIDEOPORTEIRO/TELEFONE** não é utilizável com as centrais CT/1-6 e CT/2-8.



---

[REDACTED]

---

[REDACTED]